



TAMAGAWA ELECTRONICS VIETNAM CO.,LTD



www.tmev.com.vn

COMPANY PROFILE



Management
System
ISO 9001:2015
ISO 14001:2015

www.tuv.com
ID 9108642074



Information communication is the vital infrastructure for normal activities of society. In the world of the information communication, high-frequency radio plays an essential role as a key technology. We are Tamagawa Electronics Vietnam Co., Ltd. a professional manufacturer of the high-frequency wireless technology. Since the foundation in 1968, being the parent company, Tamagawa Electronics Co., Ltd. (in Japan) has consistently considered the need of high-frequency wireless technology products for always. Our missions are manufacturing products that can meet the needs of society and contributing to the development of information and communication in near future. With currently developed technology and know-how, Tamagawa Electronics Vietnam Co., Ltd., acting as a leading expert of inherited high-frequency wireless technology, will continue to contribute to the development of society.

ABOUT

Company Name: TAMAGAWA ELECTRONICS VIETNAM CO.,LTD

Abbreviated Name: TMEV

Foundation: 10, APR, 2015

Capital: 520,000 USD

Products: Manufacture of communication equipment

Main Bank: MIZUHO BANK - VIETCOMBANK - BIDV BANK

Headquarters: RF No.7, Plot No.H-1, Thang Long Industrial park II, My Hao District Hung Yen Province, Vietnam

Sale Revenue: 4.8 Million USD (2018 year)

Factory is about: 2160m²



**GO BEYOND
THE FUTURE WITH THE HIGH FREQUENCY**

HISTORY

July **2015**

Recognized as the best industrial park expanding business From small and medium-sized enterprises in Kanagawa province

September **2015**

Starting operation

May **2016**

Starting to export POI to Japan

December **2017**

Acquired ISO 9001 & ISO 14001 certification

April **2015**

Established Tamagawa Electronics Vietnam in the Thang Long II industrial park, Hung Yen province, Vietnam

August **2015**

Rental factory is completed

November **2015**

Starting to export products to Japan

April **2017**

Starting to export products to Korea

June **2018**

Expansion of the factory
Increase of capital
Acquired commercial license

POLICIES

1

By meeting the needs of our customers with professional service and advanced products of high-frequency technology, we will further our contribution to the development of an advanced information communication society .

2

We aim at cooperating social responsibility by trying to run business and keep it transparent, doing a fair and honest business for all of our customers and giving back the achievements to stakeholders, employees and community.

3

We will bring satisfaction to our customers by devoting ourselves to teams and keeping a good performance through the entire company.

QUALITY POLICY



CERTIFICATION OF SOLIDERING



We are always striving to keep the production and manufacturing processes under Japanese quality standards, to have our customer at their best satisfaction. Through the supplying of high quality and advanced products, we will continuously contribute to the development of an advanced information communication society.

COMPANY ORGANIZATION

Our company organization is consist of two departments Management and Production Department under control of General Director . There are several groups organized by each department. Both departments complies with ISO9001, ISO14001 regulations.



TECHNOLOGY

ATTENUATOR

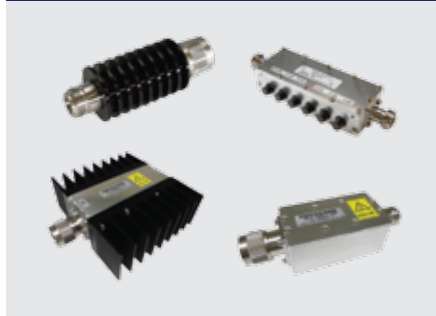

DIVIDER/SPLITTER

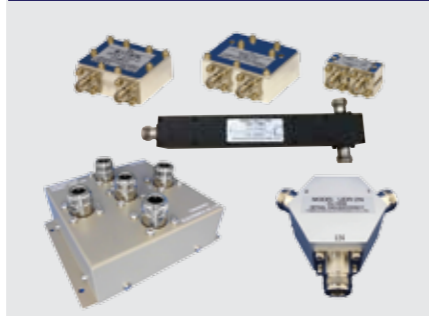

LOW AND HIGH PASS FILTER

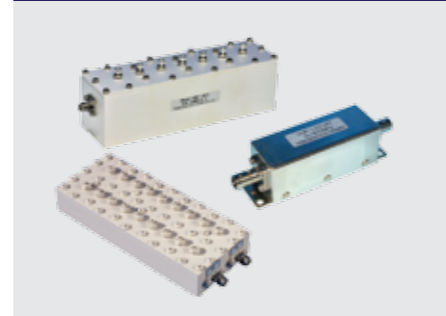

POI



TERMINATOR



COMBINER



DIRECTIONAL COUPLER



The Device group making full use of our core competency, the analog high-frequency technology, to engage in the development and manufacturing of passive components for high-frequency radio system (passive components that do not require a power supply). Products can be customized according to your needs based on our broad product portfolio such as an attenuator, switch, distributing and combining device like a duplexer and various filters. also, we offer the development of composite components of a combination of various aforementioned components.

EQUIPMENT

Frequency band of the high-frequency measurement equipment necessary for high-precision performance inspection and evaluation is supported up to DC ~ 20GHz. Impedance has both values of 50Ω/75Ω. In addition, we can obtain essential devices from the headquarters and cooperation companies in case of measuring machines are out of stock

ELECTRICAL

Name of equipment	Model	Manufacturer	Quantity
Network Analyzer (~8.5GHz)	E5071C	Agilent Technologies	2
Network Analyzer (~20GHz)	E5071C	Agilent Technologies	1
Thermostatic oven	PV-332	ESPEC	1
Amplifiers	WTPA-500T2700M46	WVE TRACK	2
Temperature & Humidity Chamber	FX420N	ETAC	1
Pimd Analyzer	AWT-APA-7/6	AWT	1

MECHANICAL

Name of equipment	Model	Manufacturer	Quantity
Digital Multifunction meter	U1232A	Agilent Technologies	1



Network Analyzer (~8.5GHz)

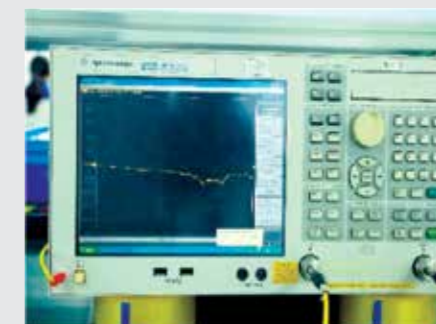

Network Analyzer (~20GHz)



Thermostatic oven



Amplifiers



Temperature & Humidity Chamber



PIMD ANALYZER

QUALITY ASSURANCE

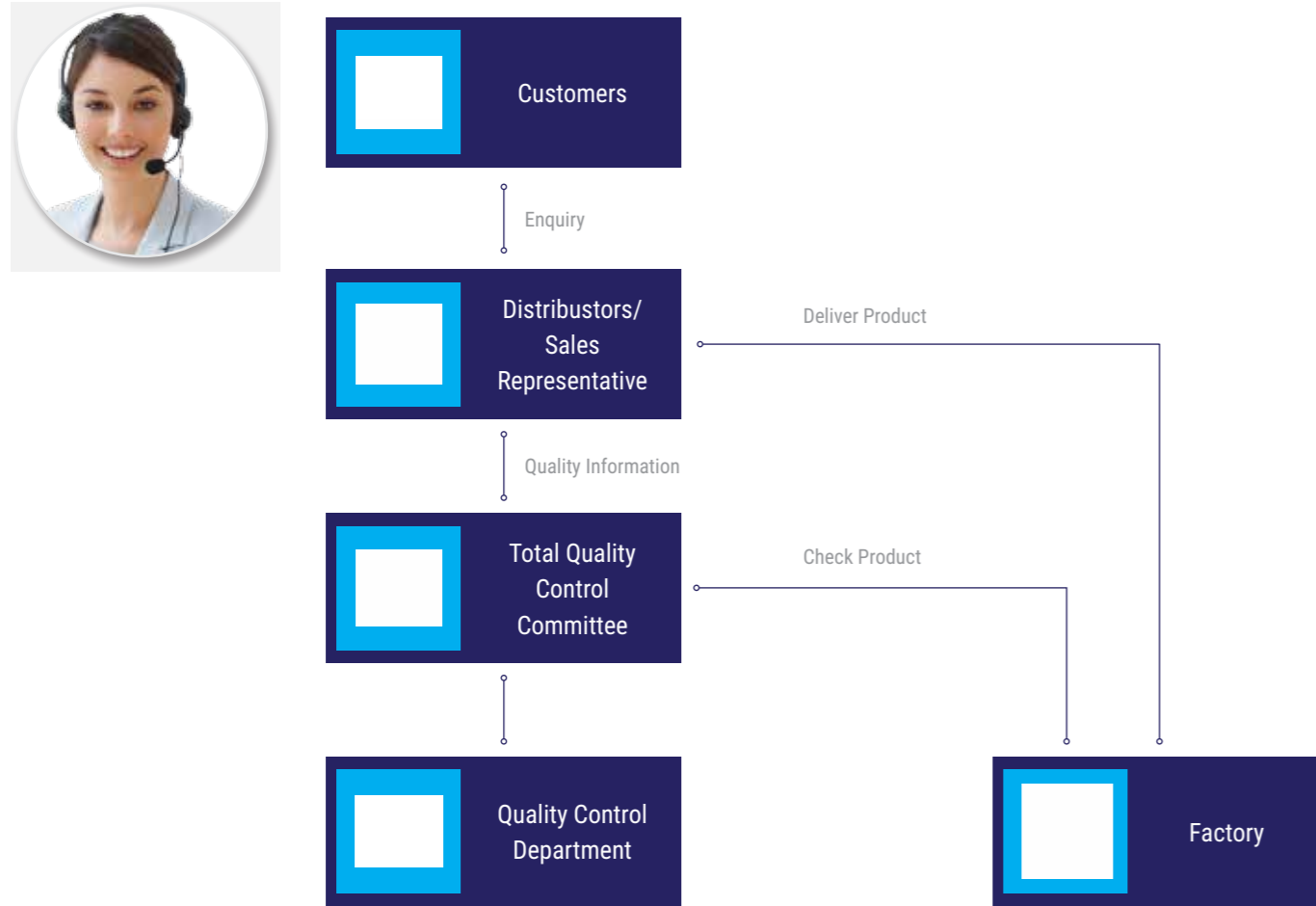

WARRANT AND REPAIRS

1. Warrant

Tamagawa electronics Vietnam warrants each product to be free from any defect in material and workmanship for one year after delivery.

The limits of liability under this warranty shall be repair or replace any products, or part which to be proved as defective after inspection by tamagawa electronics Vietnam.



This warranty shall not apply to any tamagawa electronics Vietnam products that has been disassembled, modified, physically or electrically damaged or any products that has been used at conditions exceeding the applicable specifications or rating.

2. Repairs





Repairs or calibration of tamagawa electronics Vietnam products should be made at the factory. Before returning any product, however, please contact to tamagawa electronics Vietnam or sales representative for confirming the appropriate shipping address and relative instructions. When requesting shipping instructions, please indicate the Model No., and serial No., and the nature of the difficulty or reason in details for return. The cost of repair is based on the labor and materials plus technical charge.

PRODUCT OFFERINGS

FILTER RELATED PRODUCTS

LPF and HPF	Band Pass Filter	Duplexers	Band Reject Filters
 <ul style="list-style-type: none"> • Passband: 1 to 14GHz(fo) • Impedance: 50Ω[75Ω] • Attenuation: fp x √2 or/ √2 at 20dB fp x 2 or/ 2 at 40dB 	 <ul style="list-style-type: none"> • Center Frequency Range: 300-3000MHz (fo) • Impedance: 50Ω.75Ω • 3dB BW: 3 to 10% • Input Power: 1-300W- max • Helical & Combine filter 	 <ul style="list-style-type: none"> • Center Frequency Range: 0.4 to 8GHz • Impedance: 50Ω • Insertion Loss: 0.5 to 2.0dB • Isolation: 45~85dB • Input Power: 1 to 200W max 	 <ul style="list-style-type: none"> • Reject Band: 800 to 3000MHz • Impedance: 50Ω • 3dB BW: 3% • Input Power: 10W max

SPLITTER/DIVIDER

Directional Coupler	Splitter	Hybrid Coupler	Fixed Att UFA Series
 <ul style="list-style-type: none"> • Frequency Range : 700 to 2700MHz • Impedance: 50 Ω <p>Available in 10dB and 20dB Input power: 200W</p>	 <ul style="list-style-type: none"> • Frequency Range : 700 to 2700MHz • 2/3/4Ways Splitter • Impedance: 50 Ω • Input power :300W 	 <ul style="list-style-type: none"> • Frequency range of 700 to 2700MHz • (150WMax.except 3dB) • High power coupler frequency range of 700 to 2700MHz 	 <ul style="list-style-type: none"> • Frequency Range : DC to 3000MHz • Impedance: 50 Ω • Input Power : 50W and 100 W • Attenuation Range: 3, 6, 10, 20dB

POI

POI
 <ul style="list-style-type: none"> • Input -Output type : 4-in 2-out, 6-in 2-out 8-in-2-out • Frequency:700,800,900MH z,1.5/2.0/2.7GHz

TERMINATOR

Terminator
 <ul style="list-style-type: none"> • Frequency Range : DC to 3000MHz • Impedance: 50 Ω • Input Power : 50W and 100W



FOR OUTDOOR USE (BTS SOLUTIONS)



FEATURE

For outdoor BTS application, Combiner or duplexers of GSM and LTE dual band are set up on top of tower antenna and near the BTS equipment.

Our products comply more than IP65 (water-protect), lightning, wind specification for outdoor environment.

We manufacture 2/3/4Generations combiners for BTS solution and design for 2/3/4Generations purpose with DC /AISG through functions and Low PIMD and Low insertion loss



INTERFERENCE FILTER SERIES SPECIFICATIONS

PRODUCT	800M AND 900M DUPLEXER
MODEL	DUP-1014-VE

FEATURE

Integrates Dual Bands Combiner with a 5MHz Rejection (824-875MHz - 880-960MHz)
Outdoor Application

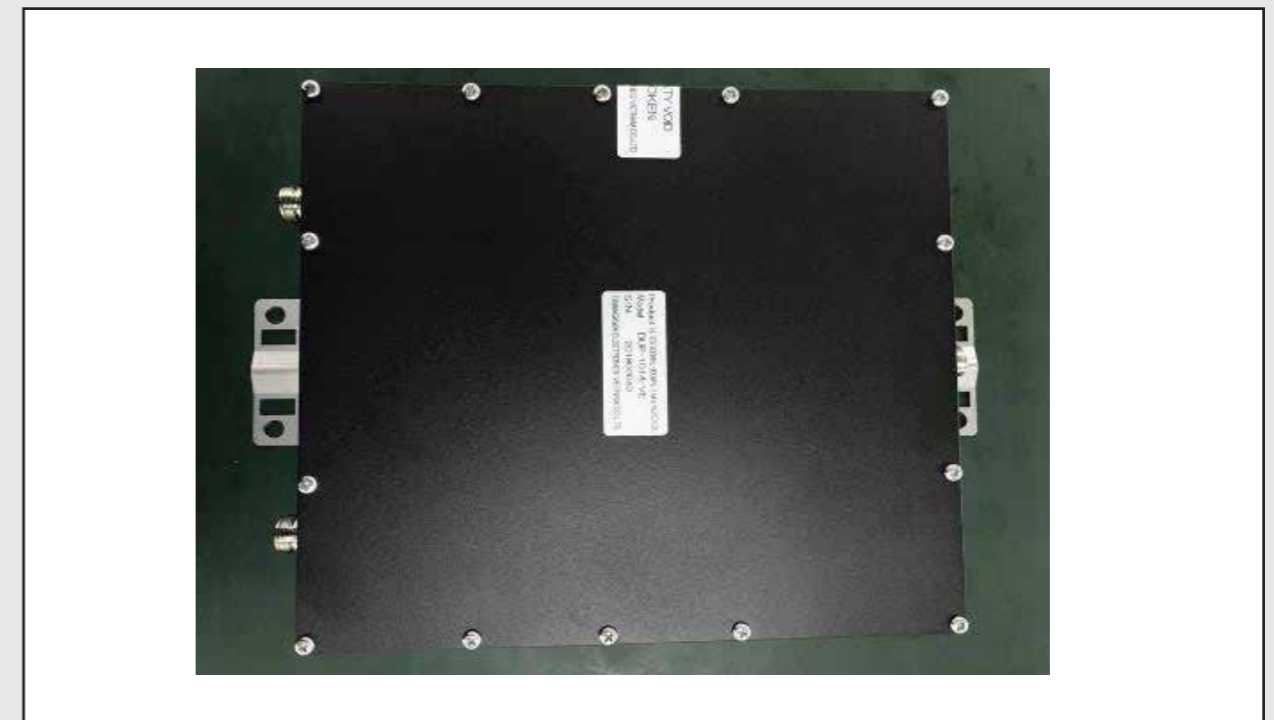

ELECTRONICAL SPECIFICATIONS

NO	COLUMN	BAND 800M	BAND 900M
1	Pass Band Frequency	824~875MHz	880~960MHz
2	Insertion loss	1.5dB Max.	1.5dB Max.
3	V.S.W.R.	1.3 Max.	1.3 Max.
4	Attenuation	50dB min @880~960MHz	50dB min @824~875MHz
5	Power (Avg.)	CW 100W Max.	
6	Impedance	50 Ω All ports	

ENVIRONMENTAL SPECIFICATIONS

7	Operating Temperature	-10 to +55°C
8	Humidity	100% non-condensing
9	Waterproofing Class	IP65

MECHANICAL SPECIFICATIONS

10	Size	225×315×80 mm
11	RF Connector	N-Female input and output ports
12	Labels	Labels as they appear in the mechanical drawings
13	Finish	Black

ELECTRICAL CHARACTERISTIC

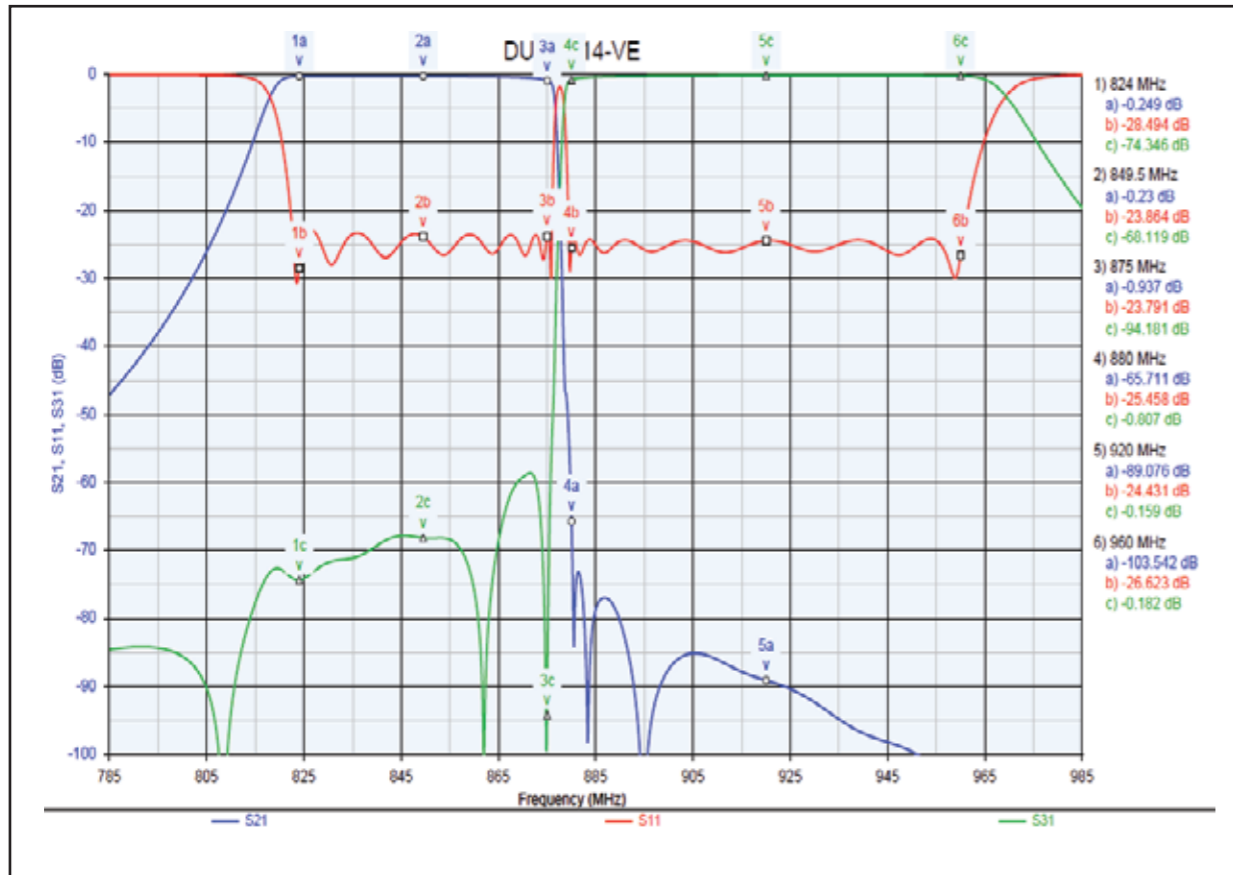

DRAWING

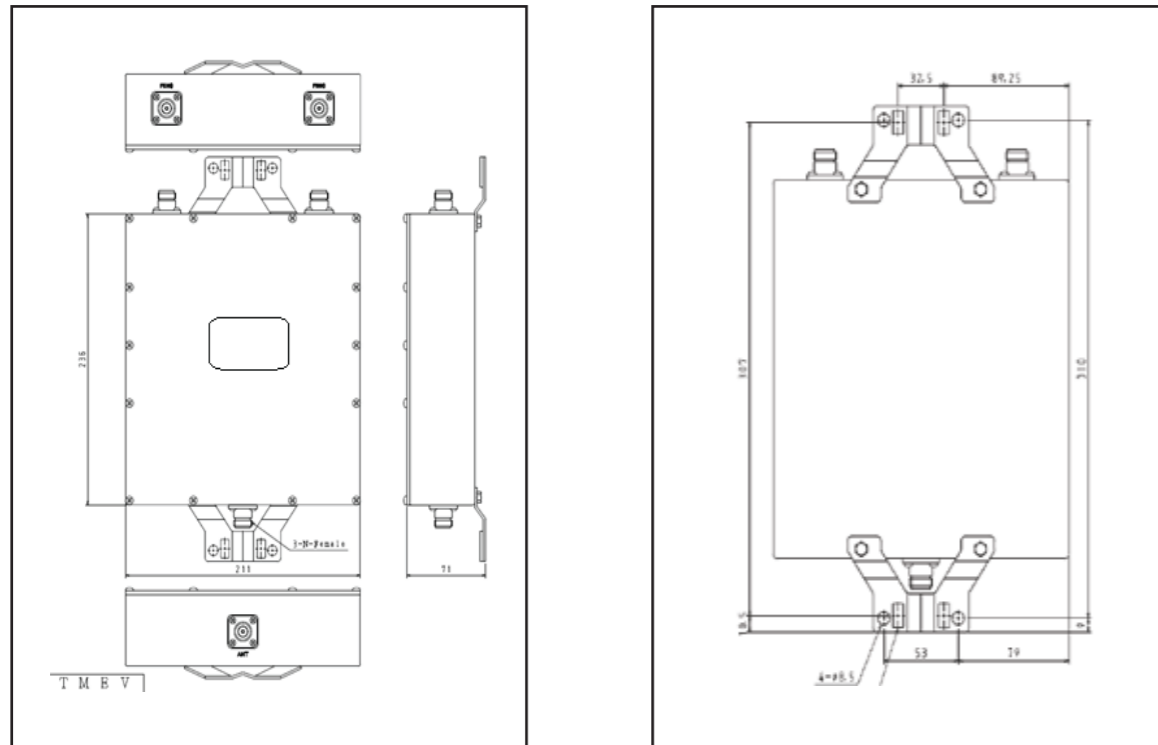

DUAL BAND COMBINER 1.8/2.1GHz

PRODUCT	DUAL BAND COMBINER 1.8/2.1GHz
MODEL	DUP-1019-VE

FEATURE

Dual Band Combiner is an antenna duplexer that shares 2 frequencies. The product is designed 1.8/2.1GHz for LTE/WCDMA System. It is equipped 2 output ports and 4 input ports and waterproof function.



ELECTRONICAL SPECIFICATIONS

NO	COLUMN	PORT1	PORT2
1	Pass Band Frequency	1710~1880MHz	1920~2170MHz
2	Insertion loss	0.4dB Max.	0.5dB Max.
3	V.S.W.R.	1.3 Max.	1.3 Max.
4	Attenuation	50dB min @1920~2170MHz	50dB min @1710~1880MHz
5	PIMD	-153 dBc (3rd order with 2x20W)	
6	Power (Avg.)	CW 250 Max.	
7	Impedance	50 Ω All ports	

ENVIRONMENTAL SPECIFICATIONS

8	Operating Temperature	-10 to +60°C
9	Humidity	0~98% ~35°C non-condensing
10	Waterproofing Class	IP66
11	Lightning Protection	3kA Lighting Surge Current Waveform 10/350 waveform 20kA Lighting Surge Current Waveform 8/20 waveform
12	RoHS Applicant	Complied

MECHANICAL SPECIFICATIONS

13	Size	259x154x106 mm
14	RF Connector	7/16 DIN-Female 4 input and 2 output ports
15	Labels	Wall or Poll
16	Finish	Beige color

ELECTRICAL CHARACTERISTIC

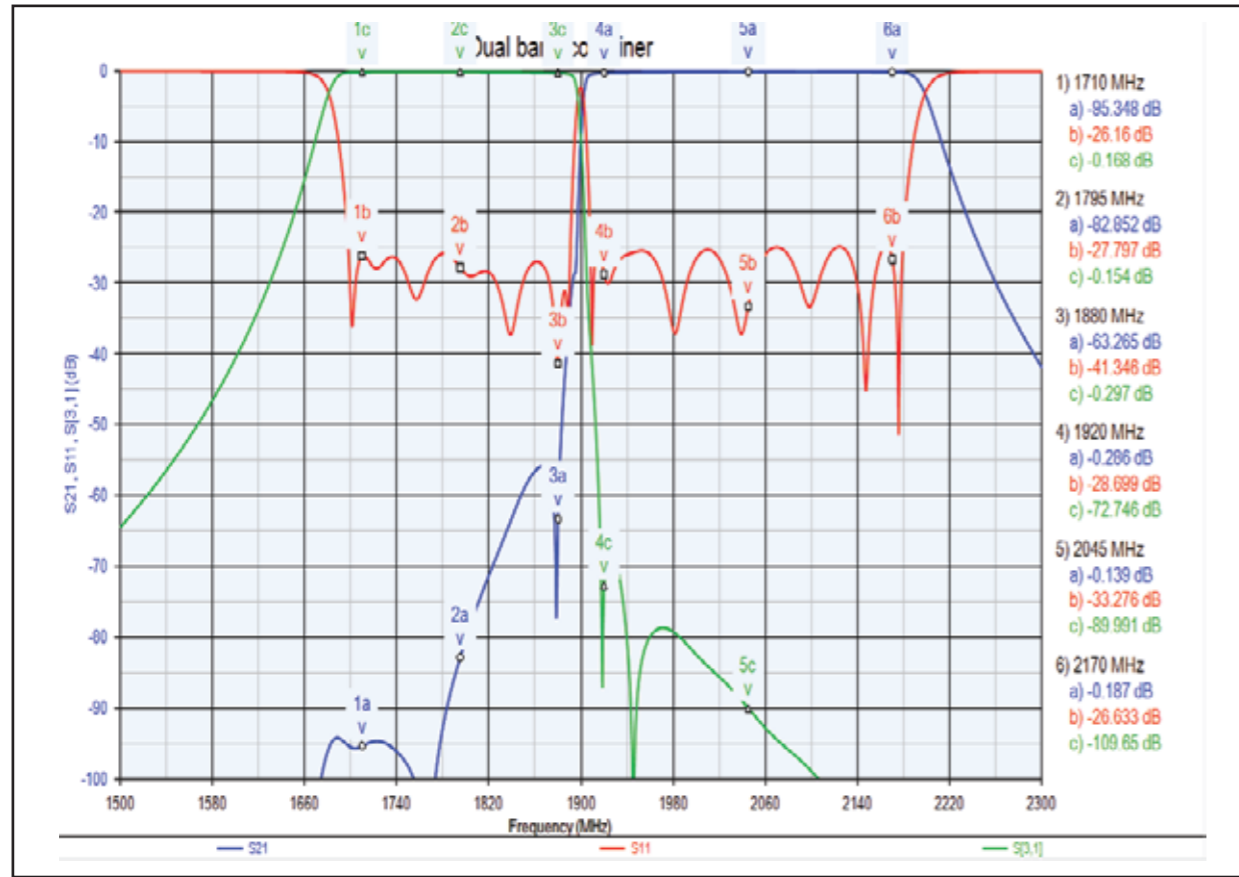

DRAWING

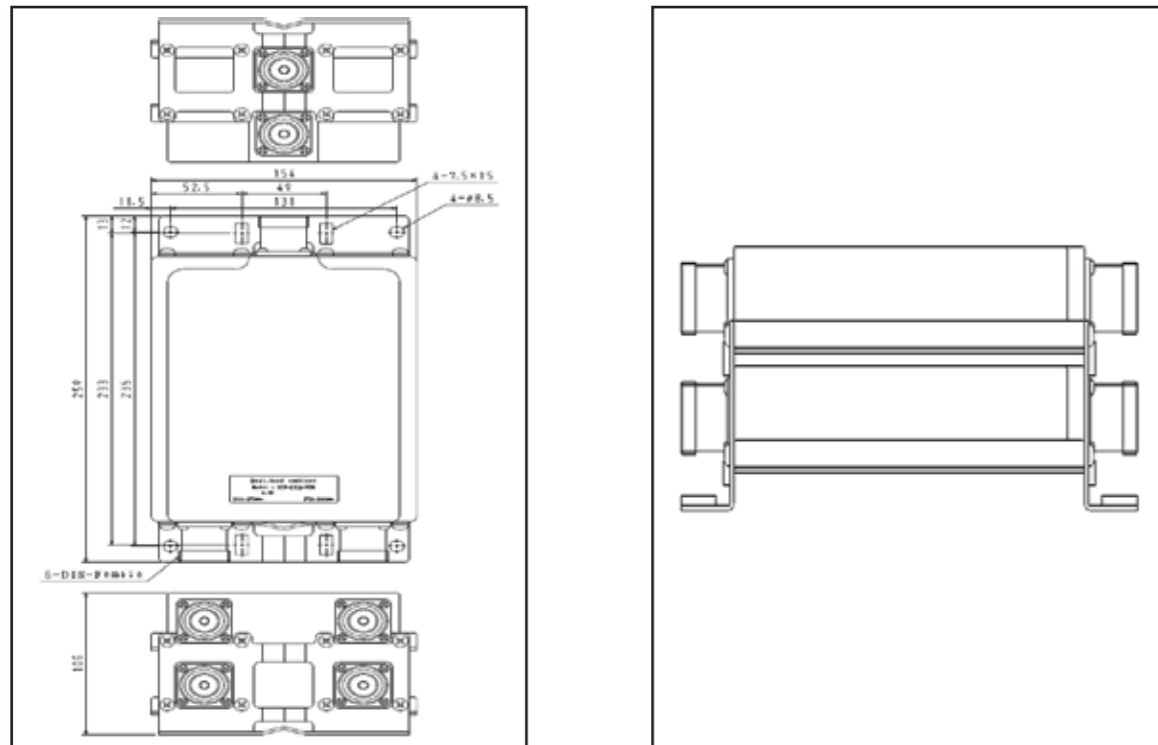

DUAL BAND COMBINER 2.1/2.6GHz

PRODUCT	DUAL BAND COMBINER 2.1/2.6GHz
MODEL	

FEATURE

Dual Band Combiner is an antenna duplexer that shares 2 frequencies. The product is designed 2.1GHz/2.6GHz for WCDMA/LTE or LTE/LTE System. It is equipped 2 output ports and 4 input ports and waterproof function IP66.



BLOCK DIAGRAM

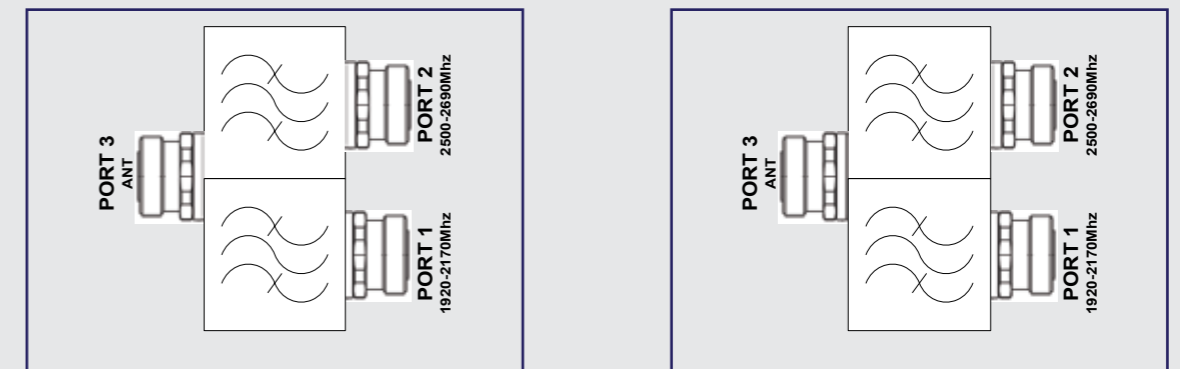

ELECTRONICAL SPECIFICATIONS

NO	COLUMN	PORT1	PORT2
1	Pass Band Frequency	1920~2170MHz	2500~2690MHz
2	Insertion loss	0.4dB Max.	
3	V.S.W.R.	1.3 Max.	
4	Attenuation	50dB min @1920~2170MHz	
5	PIMD	-153 dBc (3rd order with 2x20W)	
6	Power (Avg.)	CW 200 Max.	
7	Impedance	50 Ω All ports	

ENVIRONMENTAL SPECIFICATIONS

8	Operating Temperature	-30 to +60°C
9	Humidity	0~98% ~35°C non-condensing
10	Waterproofing Class	IP66
11	Lightning Protection	3kA Lighting Surge Current Waveform 10/350 waveform 20kA Lighting Surge Current Waveform 8/20 waveform
12	RoHS Applicant	Complied

MECHANICAL SPECIFICATIONS

13	Size	259x154x106 mm
14	RF Connector	7/16 DIN-Female 4 input and 2 output ports
15	Labels	Wall or Poll
16	Finish	Beige color

DUAL QUADRUPLER BAND COMBINER

PRODUCT	DUAL QUADRUPLER BAND COMBINER
MODEL	

FEATURE

Dual Quadruplexer Combiner is an antenna quadruplexer that shares 4 frequencies.

The product is designed 0.8/1.8/2.1/2.6GHz for GSM/LTE/WCDMA System.

It is equipped 2 output ports and 8 input ports and waterproof function.

BLOCK DIAGRAM

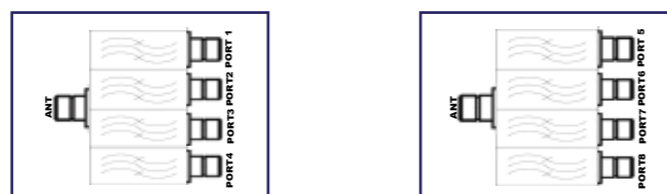

ELECTRONICAL SPECIFICATIONS

NO	COLUMN	PORT1,5	PORT2,6	PORT3,7	PORT4,8
1	Pass Band Frequency	860~960MHz	1710~1880MHz	1920~2170MHz	2500~2690MHz
2	Insertion loss	0.5dB Max.			
3	V.S.W.R.	1.2 Max.			
4	Attenuation	50dB min			
5	PIMD	-153 dBc (3rd order with 2x20W)			
6	Power (Avg.)	CW 200 Max.			
7	Impedance	50 Ω All ports			

ENVIRONMENTAL SPECIFICATIONS

8	Operating Temperature	-30 to +60°C
9	Humidity	0~98% ~35°C non-condensing
10	Waterproofing Class	IP66
11	Lightning Protection	3kA Lightning Surge Current Waveform 10/350 waveform 20kA Lightning Surge Current Waveform 8/20 waveform
12	RoHS Applicant	Complied

MECHANICAL SPECIFICATIONS

13	Size	200x230x120 mm (Height x Width x Depth)
14	RF Connector	7/16 DIN-Female 8 input and 2 output ports
15	Labels	Wall or Poll
16	Finish	Beige color

DRAWING

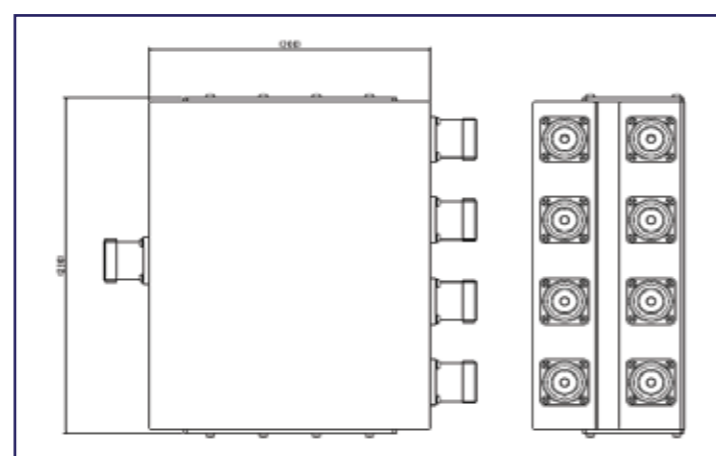

DUP-1002 SPECIFICATIONS

PRODUCT	2 WAYS COMBINER	DUP-1002-030
MODEL	DUP-1002	

FEATURE

2 ways combiner is an antenna duplexer that shares 2 frequencies. The frequency can be manufactured from 700/900/1800/2100/2700 MHz with the specified frequency of GSM / WCDMA / LTE system. It also has waterproof function so it can be installed outdoors. Low loss and low PIM are ideal for outdoor base station equipment.

BLOCK DIAGRAM

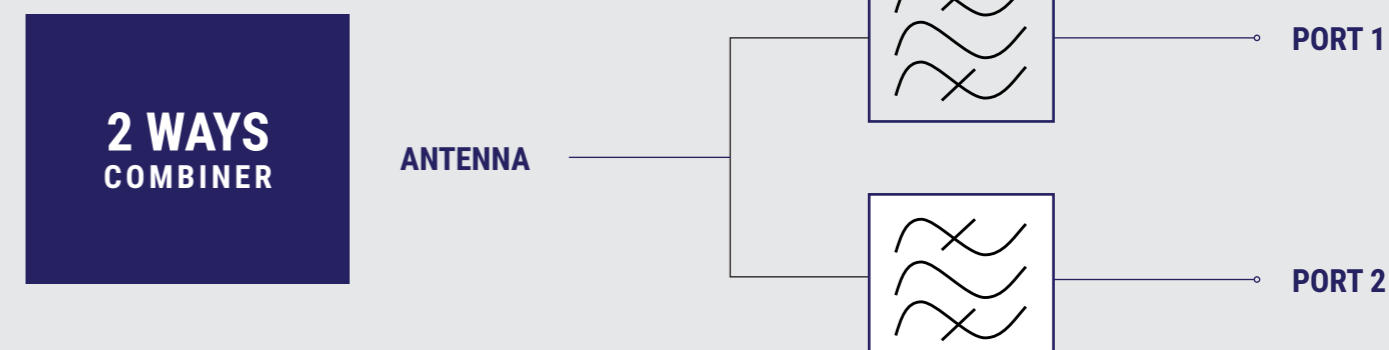

ELECTRONICAL SPECIFICATIONS

NO	COLUMN	PORT 1	PORT 2
1	Pass band frequency	※ 700 ~ 900MHz	※ 700 ~ 900MHz
		※ 1700 ~ 1880MHz	※ 1700 ~ 1880MHz
		※ 1920 ~ 2200MHz	※ 1920 ~ 2200MHz
		※ 2500 ~ 2700MHz	※ 2500 ~ 2700MHz
Please designate the one pass band frequency from above ※ Passband is permitted within 10% of above each frequency band Port 1 and Port2 must not be same Pass band frequency			
2	Insertion Loss	0.5dB MAX	0.5dB MAX
3	Pass band Ripple	0.35 dB	0.35dB
4	V.S.W.R.	1.2 MAX	1.2 MAX
5	Isolation	50dBc Min	50dBc Min
6	Impedance	50Ω	
7	PIMD	-153dBc CW 2x43dBm	
8	Average Maximum Power	200W	

ENVIRONMENTAL SPECIFICATIONS

9	Operating Temperature	-30°C ~+ 75°C
10	Storage Temperature	-40°C ~+ 85°C
11	Relative Humidity	0~95% ~+ 35°C
12	Waterproof	IP67
13	Lightning Protection	3 kA Lightning Surge Current Waveform 10/350 waveform 20 kA Lightning Surge Current Waveform 8/20 waveform
14	RoHS Applicant	200W
15	Safety	ETS300019
16	Environment	EN60950

MECHANICAL SPECIFICATIONS

17	Dimensions	W 185 × D 200 × H 50 (Not included projecting parts)		
18	Weight	3.0 kg (not included Mounting Metal Part)		
19	Connector	Antenna	DIN Female	DIN Female
20	Mouting Type	WALL		

ELECTRICAL CHARACTERISTIC

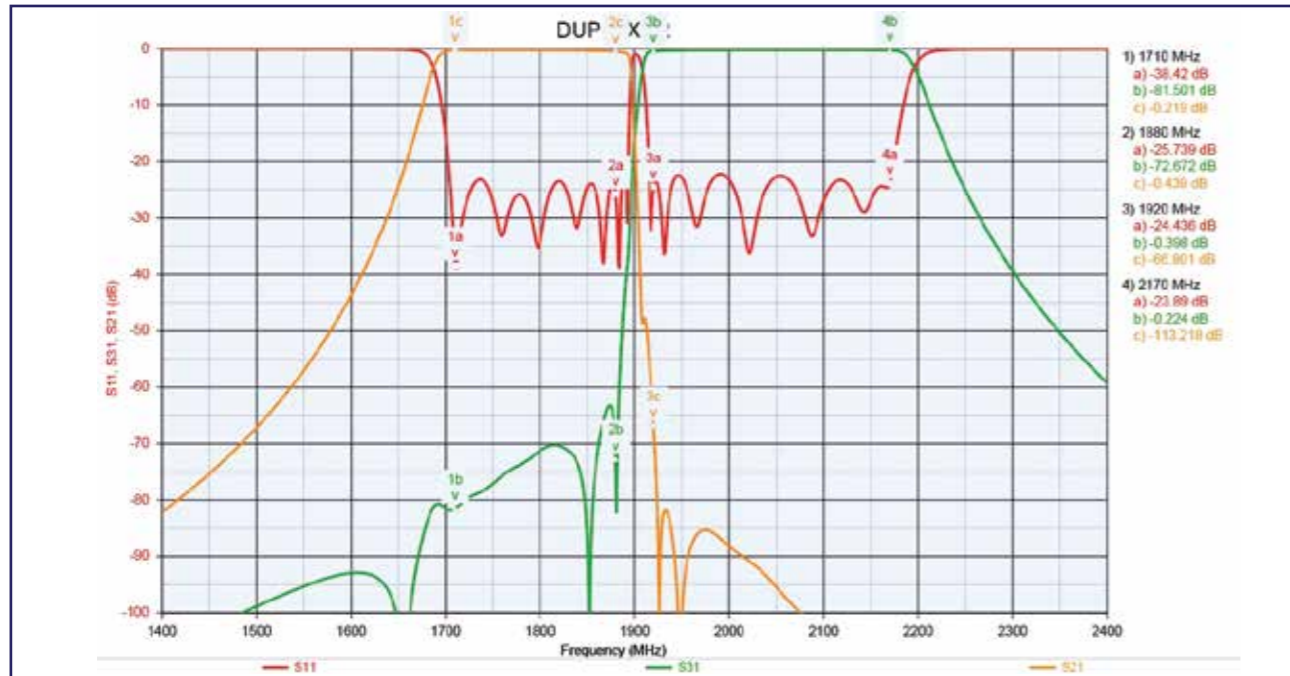

DRAWING

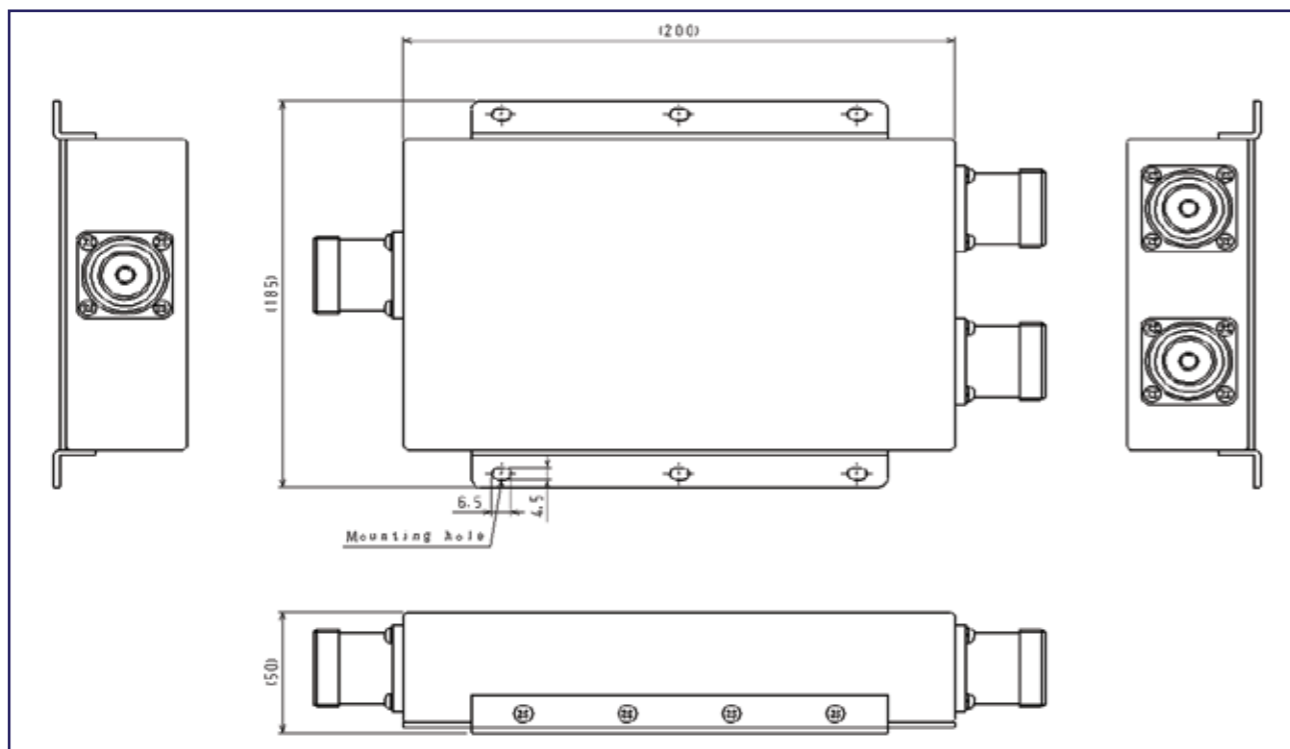

TRI-1001 SPECIFICATIONS

PRODUCT	3 WAYS COMBINER	TRI-1001-030
MODEL	TRI-1001	

FEATURE

3 ways combiner is an antenna duplexer that shares 3 frequencies. The frequency can be manufactured from 700/900/1800/2100/2700 MHz with the specified frequency of GSM / WCDMA / LTE system. It also has waterproof function so it can be installed outdoors. Low loss and low PIM are ideal for outdoor base station equipment.

BLOCK DIGRAM

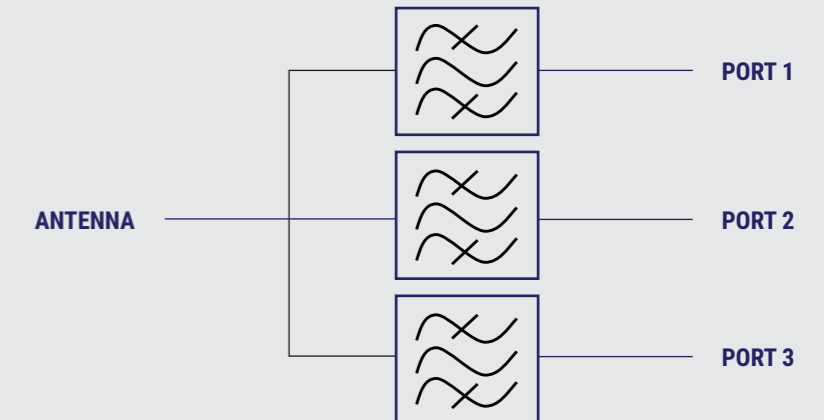

ELECTRONICAL SPECIFICAITONS

NO	COLUMN	PORT 1	PORT 2	PORT 3
1	Pass band frequency	× 700 ~ 900MHz	× 700 ~ 900MHz	× 700 ~ 900MHz
		× 1700 ~ 1880MHz	× 1700 ~ 1880MHz	× 1700 ~ 1880MHz
		× 1920 ~ 2200MHz	× 1920 ~ 2200MHz	× 1920 ~ 2200MHz
		× 2500 ~ 2700MHz	× 2500 ~ 2700MHz	× 2500 ~ 2700MHz
Please designate the one pass band frequency from above × Passband is permitted within 10% of above each frequency band Port 1, Port 2 and Port 3 must not be same Pass band frequency				
2	Insertion Loss	0.5dB MAX	0.5dB MAX	0.5dB MAX
3	Pass band Ripple	0.35 dB	0.35 dB	0.35dB
4	V.S.W.R.	1.2 MAX	1.2 MAX	1.2 MAX
5	Isolation	50dBc Min	50dBc Min	50dBc Min
6	Impedance	50Ω		
7	PIMD	-153dBc CW 2×43dBm		
8	Average Maximum Power	200W		

ENVIROMENTAL SPECIFICATIONS

9	Operating Temperature	-30°C ~ +75°C
10	Storage Temperature	-40°C ~ +85°C
11	Relative Humidity	0~95% ~ +35°C
12	Waterproof	IP67
13	Lighting Protection	3 kA Lightning Surge Current Waveform 10/350 waveform 20 kA Lightning Surge Current Waveform 8/20 waveform
14	RoHS Applicant	200W
15	Safety	ETS300019
16	Environment	EN60950

MECHANICAL SPECIFICATIONS

17	Dimensions	W 230 × D 200 × H 50 (Not included projecting parts)			mm
18	Weight	3.0 kg (not included Mounting Metal Part)			
19	Connector	Antenna	DIN Female	Port 1&2	DIN Female
20	Mouting Type	WALL			

ELECTRICAL CHARACTERISTIC

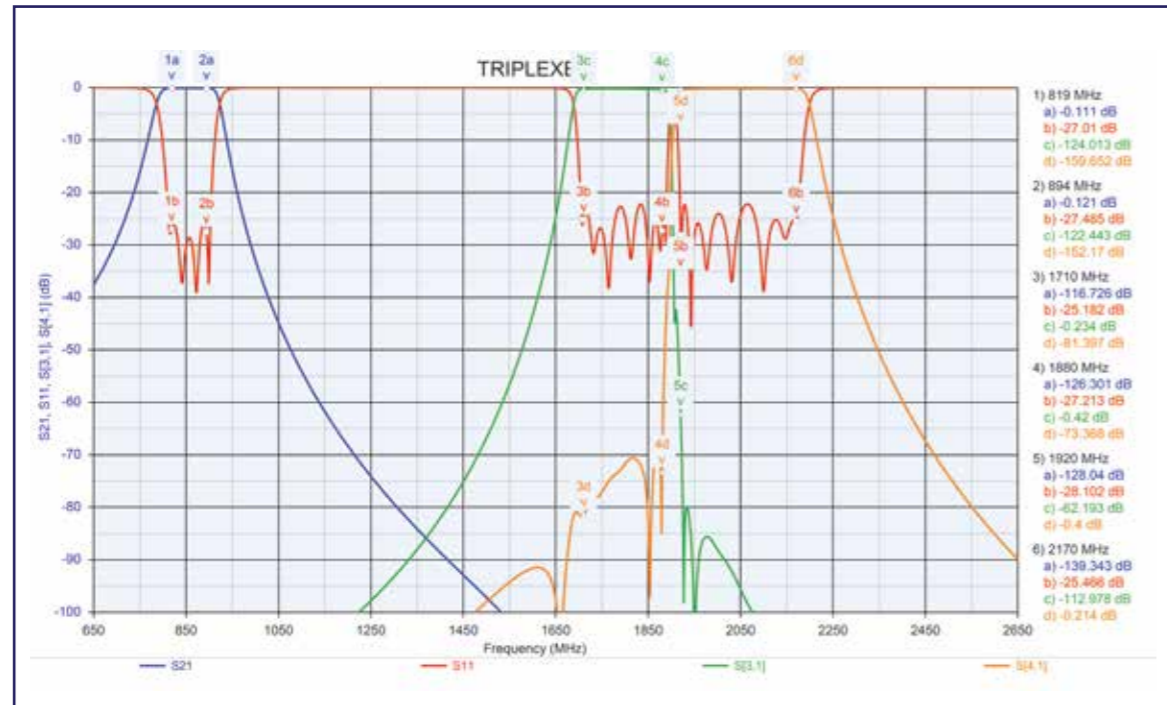

DRAWING

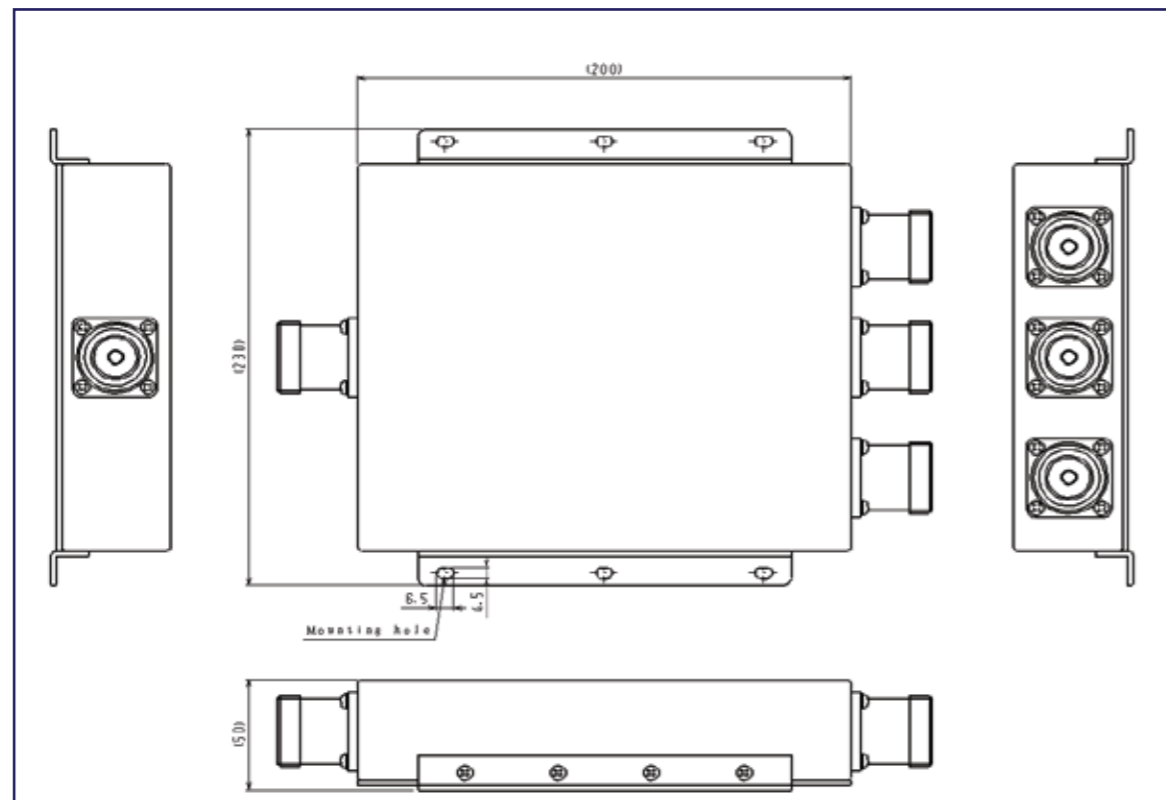

QUD-1003 SPECIFICATIONS

PRODUCT	4 WAYS COMBINER	QUD-1003-030
MODEL	QUD-1003	

FEATURE

4 ways combiner is an antenna duplexer that shares 4 frequencies. The frequency can be manufactured from 700/900/1800/2100/2700 MHz with the specified frequency of GSM / WCDMA / LTE system. It also has waterproof function so it can be installed outdoors. Low loss and low PIM are ideal for outdoor base station equipment.

BLOCK DIGRAM

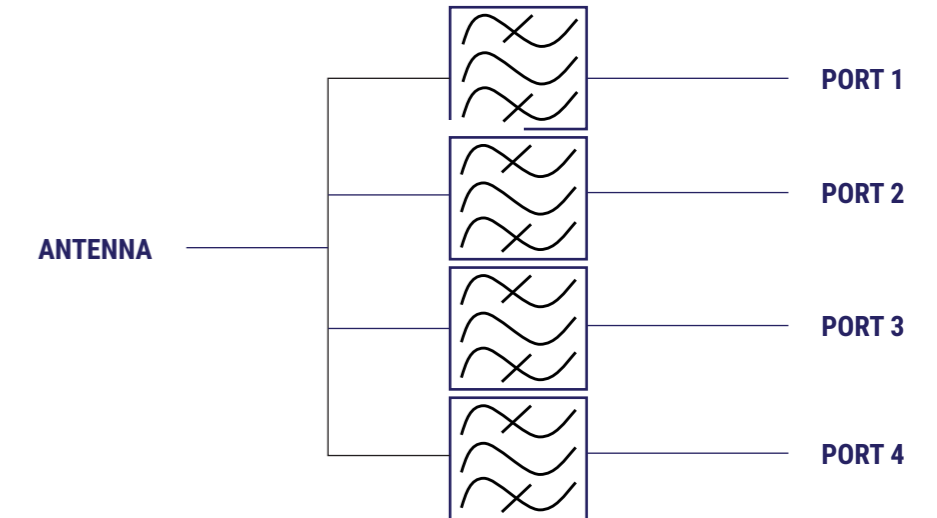

ELECTRONICAL SPECIFICATION

NO	COLUMN	PORT 1	PORT 2	PORT 3	PORT 4
1	Pass band frequency	※700 ~ 900MHz	※1700 ~ 1880MHz	※1920 ~ 2200MHz	※2500 ~ 2700MHz
		※ Passband is permitted within 10% of above each frequency band			
2	Insertion Loss	0.5dB MAX	0.5dB MAX	0.5dB MAX	0.5dB MAX
3	Pass band Ripple	0.35 dB	0.35 dB	0.35 dB	0.35dB
4	V.S.W.R.	1.2 MAX	1.2 MAX	1.2 MAX	1.2 MAX
5	Isolation	50dBc Min	50dBc Min	50dBc Min	50dBc Min
6	Impedance	50Ω			
7	PIMD	-153dBc CW 2×43dBm			
8	Average Maximum Power	200W			

ENVIRONMENTAL SPECIFICATIONS

9	Operating Temperature	-30°C ~+ 75°C
10	Storage Temperature	-40°C ~+ 85°C
11	Relative Humidity	0~95% ~+ 35°C
12	Waterproof	IP67
13	Lighting Protection	3 kA Lightning Surge Current Waveform 10/350 waveform 20 kA Lightning Surge Current Waveform 8/20 waveform
14	RoHS Applicant	Applied
15	Safety	ETS300019
16	Environment	EN60950

MECHANICAL SPECIFICATIONS

17	Dimensions	W 250 × D 200 × H 50 (Not included projecting parts)		mm	
18	Weight	4.0 kg (not included Mounting Metal Part)			
19	Connector	Antenna	DIN Female	Port 1&2	DIN Female
20	Mouting Type	WALL			

DRAWING

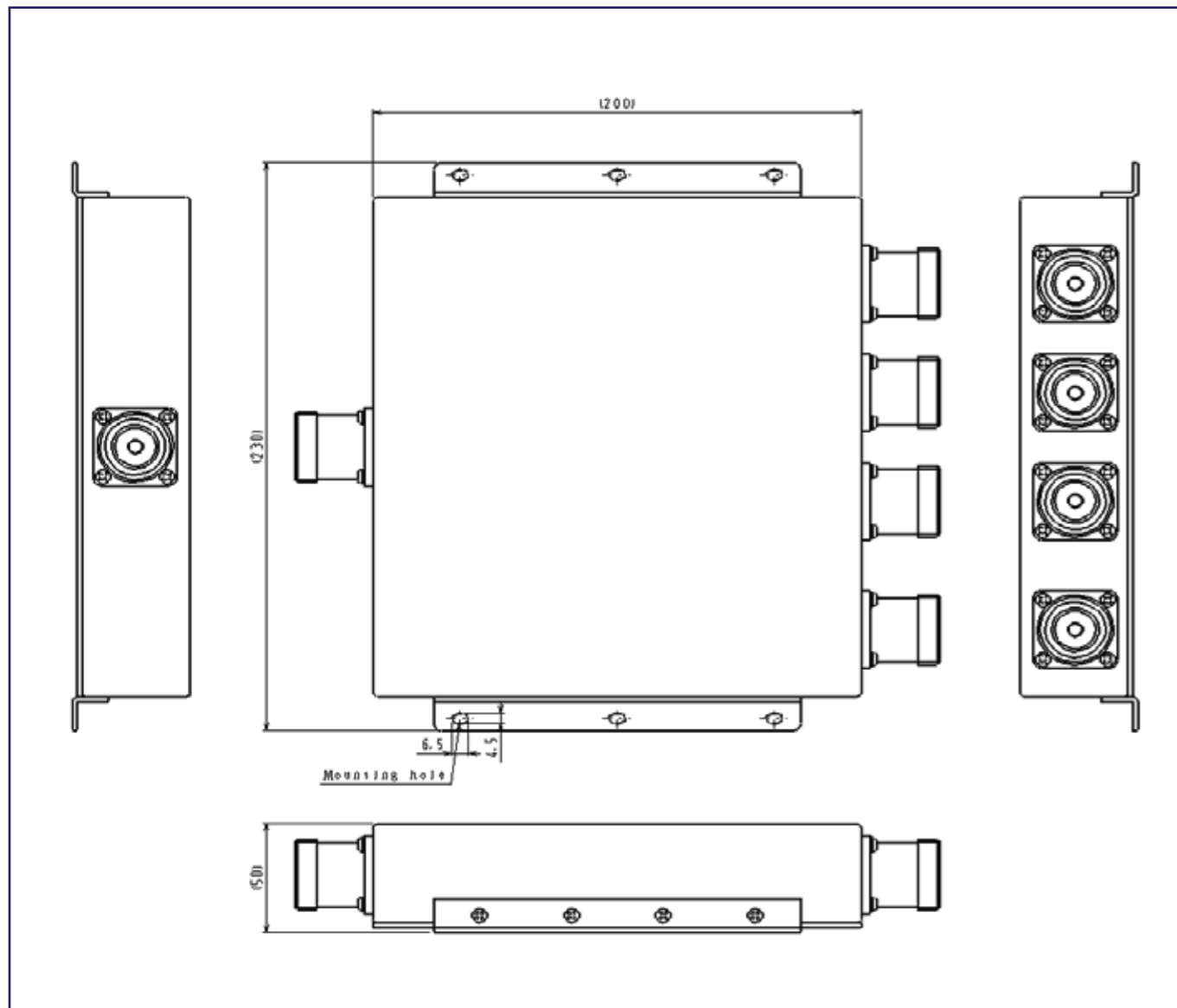

VARIOUS DUPLEXER SERIES

PRODUCT	VARIOUS DUPLEXER SERIES
MODEL	

FEATURE

These duplexer for various purpose of telecommunication equipment for outdoor use

ELECTRONICAL SPECIFICAITONS

850MHz DUPLEXER(DUP-1046)

NO	COLUMN	UL PORT	DL PORT
1	Pass Band Frequency	824-827MMHz	869-879MHz
2	Insertion loss	0.7dB max	

900MHz DUPLEXER(DUP-1048)

UL PORT	DL PORT
882-915MHz	927-960MHz
1.2dB max	

1800MHz DUPLEXER(DUP-1050)

NO	COLUMN	UL PORT	DL PORT
1	Pass Band Frequency	1710-1780MHz	1805-1880MHz
2	Insertion loss	1.2dB max	

2100MHz DUPLEXER(DUP-1052)

DL PORT	DL PORT
1922-1978MHz	2112-2168MHz
0.7dB max	

COMMON ELECTRIACL SPECIFICATIONS

NO	V.S.W.R.	1.2 Max.
3	Isolation between UL and DL	60dB min
4	PIMD	-153 dBc (3rd order with 2x20W)
5	DC pass	DC 30V - 2.5A (max 50V)
6	Power (Avg.)	CW 100 Max.
7	Impedance	50 Ω All ports

ENVIROMENTAL SPECIFICATIONS

8	Operating Temperature	-30 to +60°C
9	Humidity	0~98% ~35°C non-condensing
10	Waterproofing Class	IP65
11	RoHS Applicant	Complied

MECHANICAL SPECIFICATIONS

7	Size	-10 to +55°C
8	RF Connector	0~98% ~35°C non-condensing
9	RoHS Applicant	IP65

MECHANICAL SPECIFICATIONS

10	Size	Referring to drawing
11	RF Connector	7/16 DIN-Female 2 input and 1 output port
12	Mounting	Wall or Poll
13	Finish	Beige color

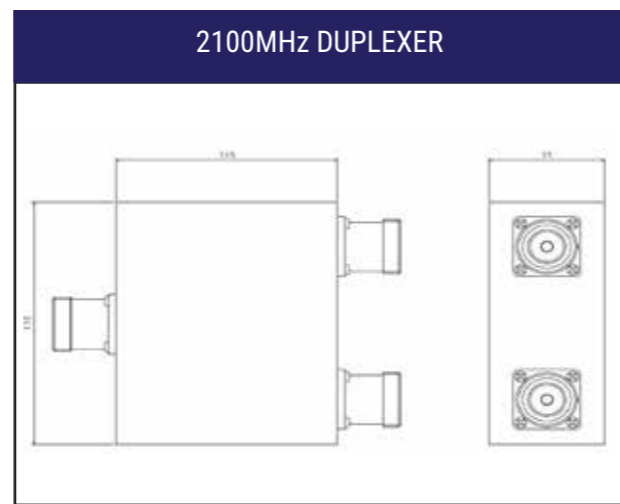
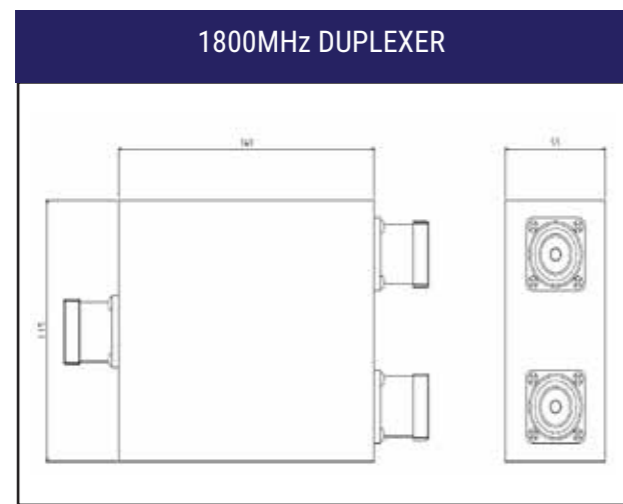
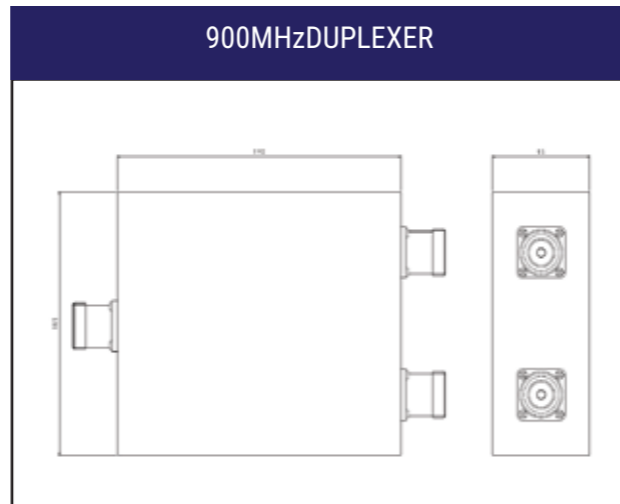
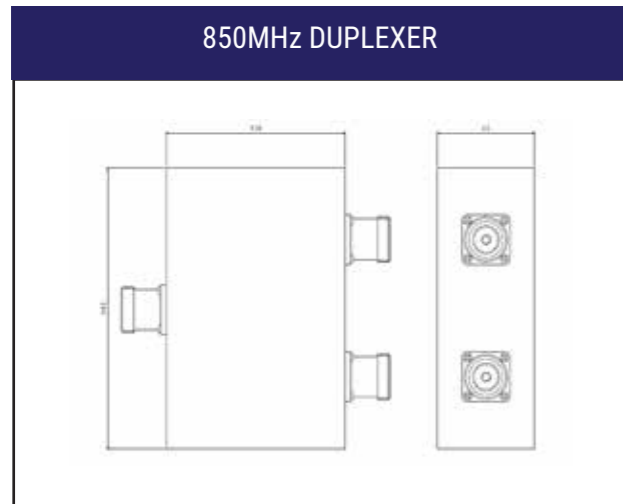

4WAYS COMBINER

PRODUCT	4WAYS COMBINER
MODEL	DIV-1003/1004-UE

FEATURE

4 way combiner for combining 4 same frequency and output to 1 port . Products for 1.8GHz and 2.1GHz

BLOCK DIAGRAM

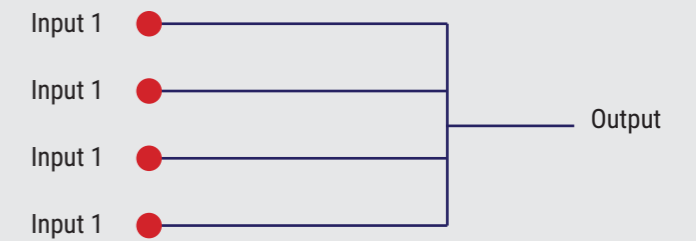

ELECTRONICAL SPECIFICATIONS

NO	COLUMN	DIV-1003-UE	DIV-1004-UE
1	Pass Band Frequency	1710-1880MHz	1920~2170MHz
2	Insertion loss	6.6dB Max.	6.7dB Max.
3	V.S.W.R.	1.2 Max.	
4	Isolation	18dB min.	
5	Power (Avg.)	CW 50 Max.	
6	Impedance	50 Ω All ports	

ENVIRONMENTAL SPECIFICATIONS

8	Operating Temperature	-20 to +60°C
9	Humidity	5~95% ~35°C non-condensing
10	Waterproofing Class	IP67
11	RoHS Applicant	Complied

MECHANICAL SPECIFICATIONS

13	Size	200x80x43 mm
14	RF Connector	7/16 DIN-Female 4 input and 1 output port
15	Mounting	Wall or Poll 6-M3
16	Finish	Beige color

ACUTUAL DATA

Frequency	1900-2200MHz		
V.S.W.R.	1.25 max	ANT	1.15
		WCDMA (1)	1.2
		WCDMA (2)	1.22
		WCDMA (3)	1.18
		WCDMA (4)	1.19
Insertion loss	6.9dB max	ANT - WCDMA (1)	6.79
		ANT - WCDMA (2)	6.53
		ANT - WCDMA (3)	6.36
		ANT - WCDMA (4)	6.38
		WCDMA (1) - WCDMA (2)	21.6
Isolation	18dB min	WCDMA (2) - WCDMA (3)	27.5
		WCDMA (3) - WCDMA (4)	19.1
		WCDMA (4) - WCDMA (1)	28.6

FOR INDOOR USE (IN BUILDING - SOLUTION)



■ In mobile communication base station, in order to cover the area inside the high-rise building and underground, the indoor communication area is built by the indoor antenna sharing system (DAS).

■ We supply the passive components required for antenna wiring, such as base station antenna, duplexers splitter, coupler, and coaxial attenuators for level adjustment.

■ We support frequency is covering 700MHz up to 2700MHz for 2/3/4G GSM,W-CDMA,LTE system.

DRAWING

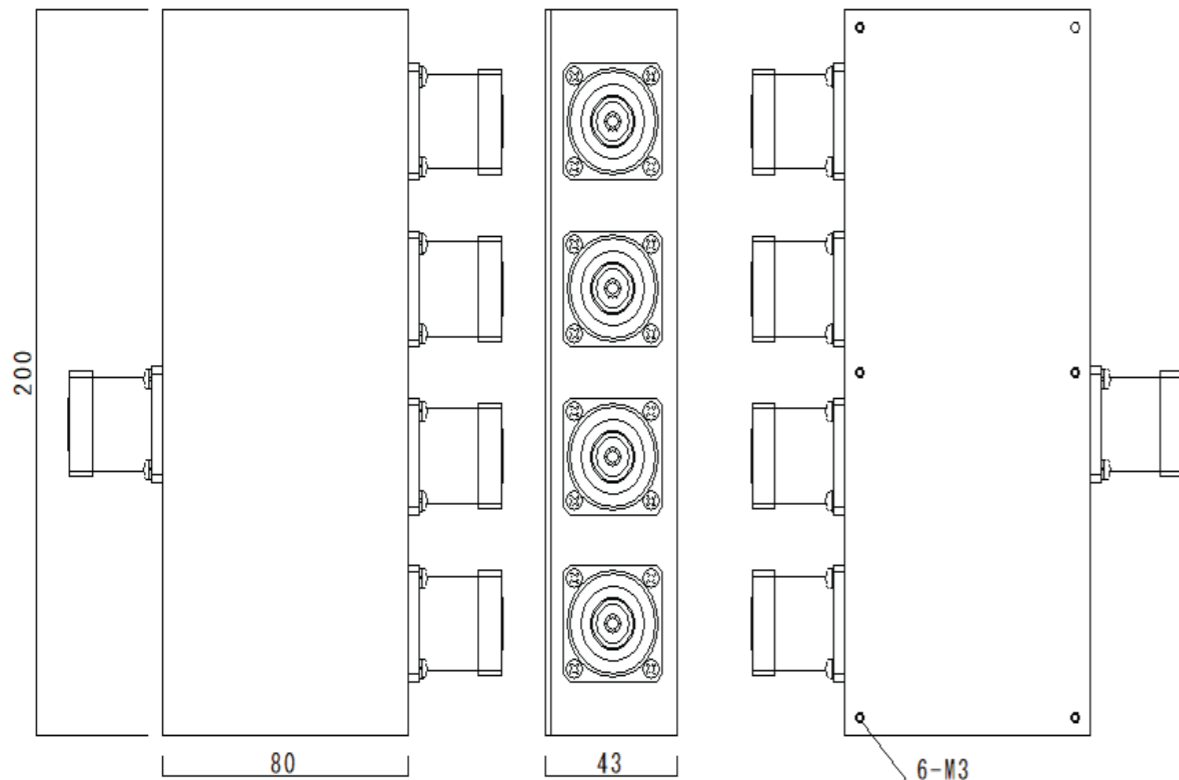

DRAWING



DIV -SERIES SPECIFICATIONS

PRODUCT	SPLITTER
MODEL	DIV SERIES

FEATURE

We have 3 types of splitters and there are 2/3/4 distributor variations. It is used as a distributor for distributing antennas of IBS base stations and covers frequencies up to 700-2700 MHz, so it can be used for various mobile systems.

PICTURE



ELECTRONICAL SPECIFICATIONS

NO	MODEL	DIV - 1000	DIV - 1001	DIV - 1002
1	Frequency	700-2700MHz		
2	Insetiton Loss	≤3.4dB	≤5.2dB	≤6.4dB
3	V.S.W.R.	≤1.3 @Antenna port		
4	Impedance	50Ω		
5	PIMD	-150dBc CW 2×43dBm		
6	Average Maximum Power	300W		

ENVIROMENTAL SPECIFICATIONS

7	Operating Temperature	-35°C ~+ 75°C		
8	Storage Temperature	-45°C ~+ 85°C		
9	Relative Humidity	5~95% @+ 35°C		
10	Lighting Protection	Non-applied		
11	RoHS Applicant	Applied		
12	Safety	ETS300019		
13	Environment	EN60950		

MECHANICAL SPECIFICATIONS

15	Dimensions	W 30 × D 200 × H 30 (Not included projecting parts)		mm	
16	Weight	450g		550g	650g
17	Connector	Input	N_FEMALE	Output	N_FEMALE

DIV-1000 (Insertion loss vs VSWR)

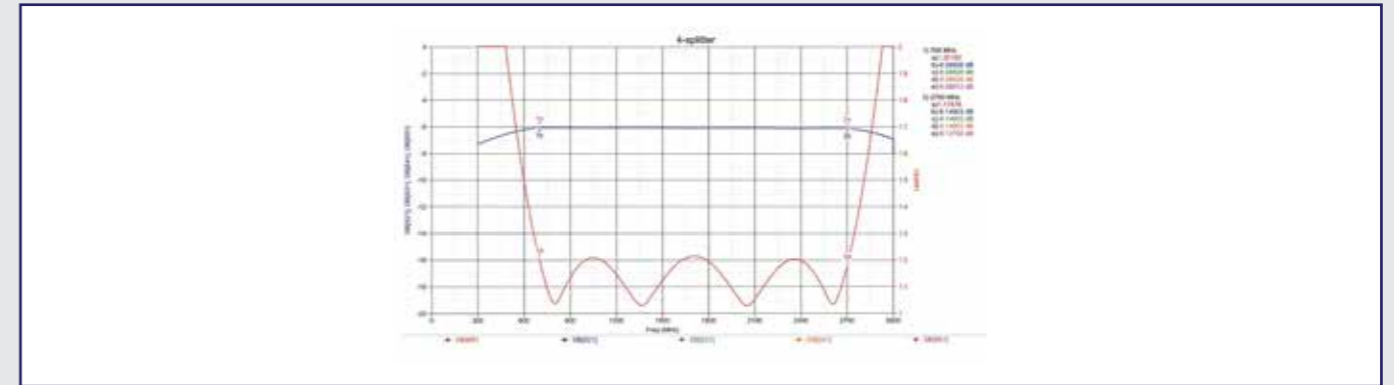

DRAWING

DIV 1000



DIV 1001



DIV 1002



CPL-SERIES SPECIFICATIONS

PRODUCT	DIRECTIONAL COUPLERS
MODEL	CPL SERIES

FEATURE

7 type of couplers are prepared, and the 3 dB coupler is available in N type and DIN type. It is used as a distributor for distributing antennas of IBS base stations and covers frequencies up to 700-2700 MHz, so it can be used for various mobile systems.

PICTURE

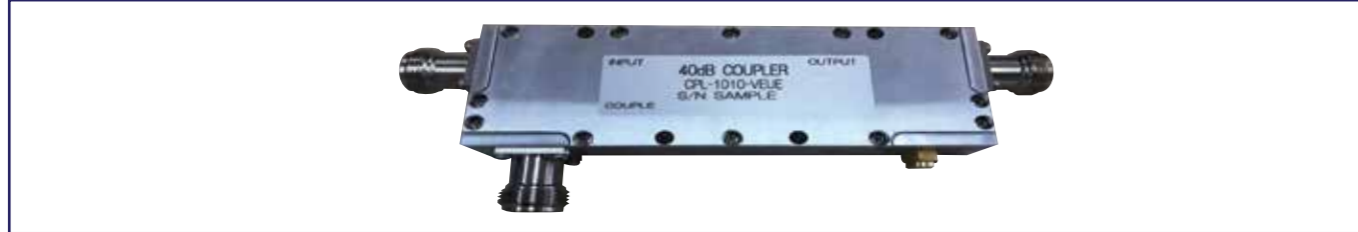

ELECTRONICAL SPECIFICATIONS

NO	COLUMN	CPL 1009	CPL1000	CPL1005	CPL1006	CPL1003	CPL1004	CPL1007
1	Frequency	700-2700MHz						
2	InsetionLoss (Input-Output1)	≤3.8 dB	≤3.4dB	≤1.5dB	≤1.3dB	≤0.7dB	≤0.3dB	≤0.3dB
3	V.S.W.R	1.2						
4	Couple(Input -Output2)	3±0.8dB	3±1dB	7±1dB	8±1dB	10±1dB	20±1dB	30±1dB
5	Directivity	≥20dB	≥20dB					
6	Impedance	50Ω						
7	PIMD	-153dBc CW 2×43dBm						
8	Average MAX Power	200W						

ENVIROMENTAL SPECIFICATIONS

9	Operating Temperature	-25°C ~ 75°C
10	Storage Temperature	-30°C ~ 80°C
11	Relative Humidity	5~95%RH @+ 35°C
12	Lighting Protection	Non-applied
13	RoHS Applicant	Applied
14	Safety	ETS300019
15	Environment	EN60950

MECHANICAL SPECIFICATIONS

MODEL	CPL 1009	CPL 1000 CPL 1003 CPL 1004 CPL 1005 CPL 1006 CPL 1007
17	Dimensions 118 × 35 × 19 (Not included projecting parts)	W155 × D40 × H 20 (Not included projecting parts)
18	Weight 350g	480g
19	Connector N-FEMALE	N-FEMALE
20	Mouting Type 4-Φ4 TH.	

CPL-1009(Insertion loss vs VSWR)

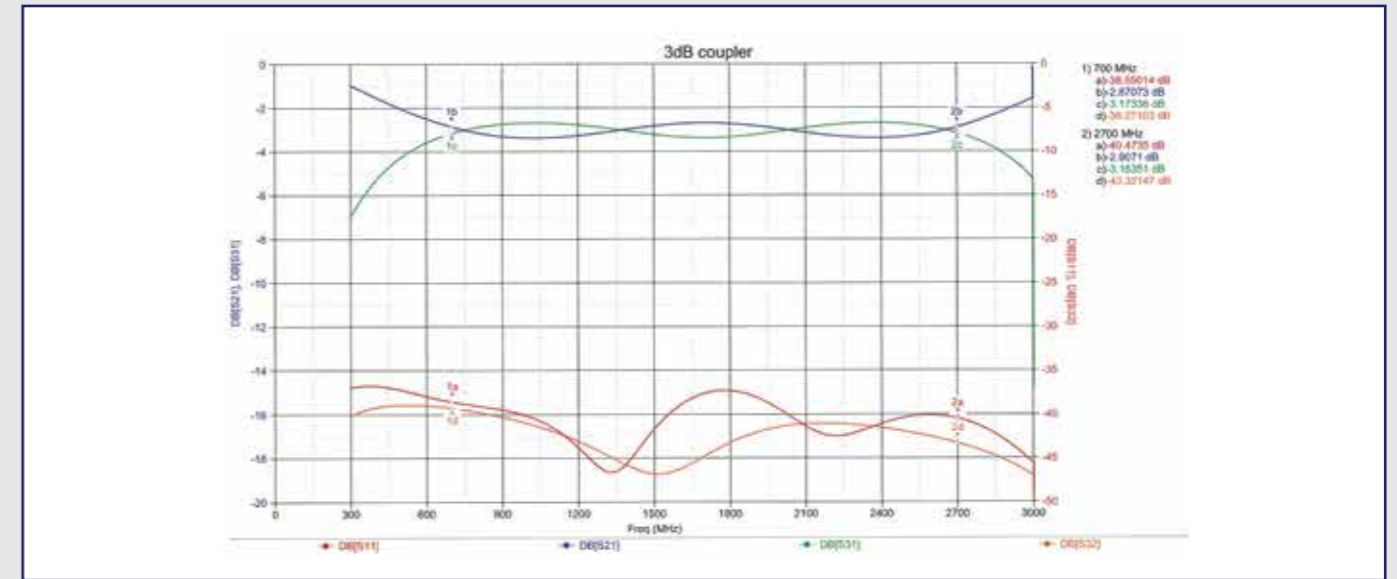

DRAWING

CPL 1009 (3DB HBRID COUPLER)

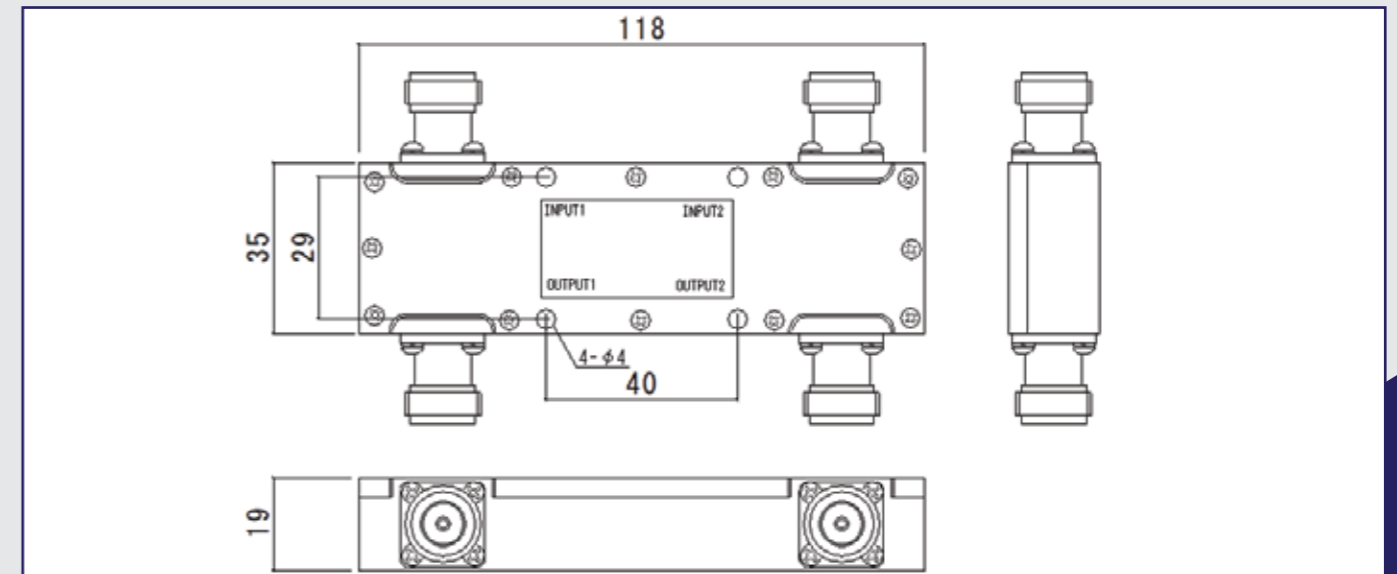

CPL1000/1005/1006/1003/1004/1007

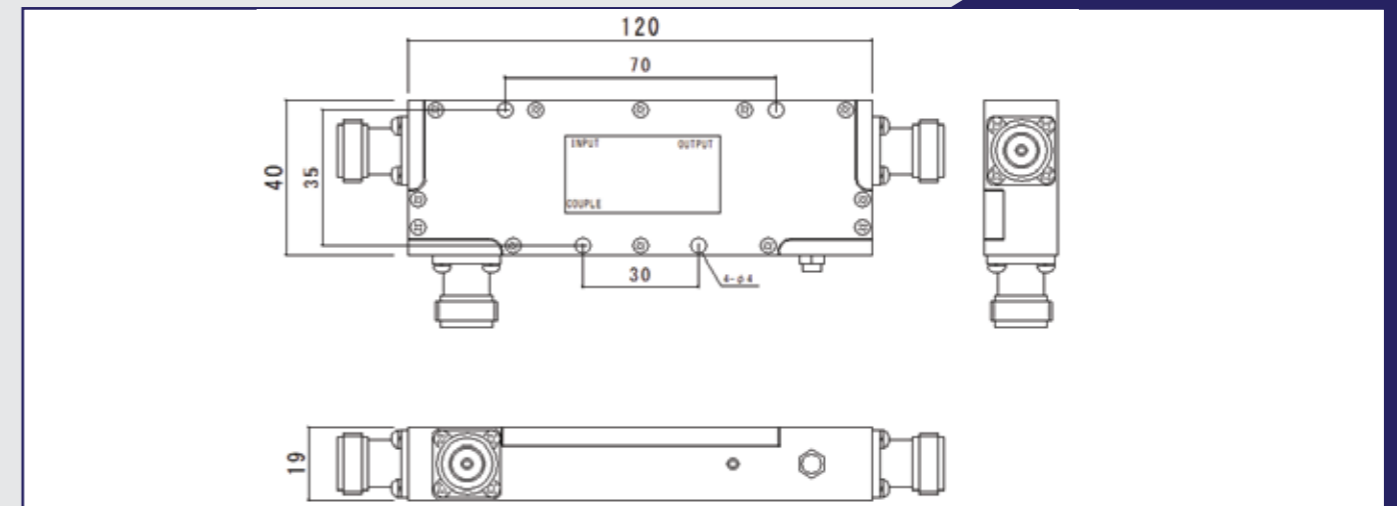

CEC-1001 SPECIFICATIONS

PRODUCT	POI (4INPUT 2OUT)	CEC-1001-030
MODEL	CEC-1001	

FEATURE

This POI is composed of 4 inputs and 2 outputs. The frequency can be manufactured from 700/900/1800/2100/2700 MHz with the specified frequency of GSM / WCDMA / LTE system. It is suitable for IBS base station products.

BLOCK DIGRAM

**4 INPUT
2 OUT**

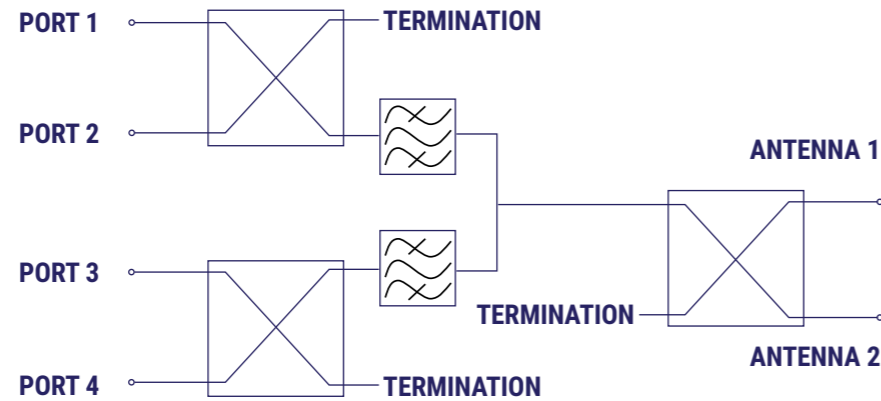

ELECTRONICAL SPECIFICATIONONS

NO	COLUMN	PORT 1,2	PORT 3,4
1	Pass band frequency	※ 700 ~ 900MHz	※ 700 ~ 900MHz
		※ 1700 ~ 1880MHz	※ 1700 ~ 1880MHz
		※ 1920 ~ 2200MHz	※ 1920 ~ 2200MHz
		※ 2500 ~ 2700MHz	※ 2500 ~ 2700MHz
		Please designate the one pass band frequency from above ※ Passband is permitted within 10% of above each frequency band Port 1 and Port2 must not be same Pass band frequency	
2	Insertion Loss	9.5dB MAX	9.5dB MAX
3	V.S.W.R.	1.35 MAX	1.35 MAX
4	Isolation		
	In Band	23dBc Min	23dBc Min
	Inter Bands	50dBc Min	50dBc Min
5	Impedance	50Ω	
6	PIMD	-153dBc CW 2x43dBm	
7	Average Maximum Power	80W MAX. per input port 320W MAX. Total input power at +22 room temp.	

ENVIROMENTAL SPECIFICATIONS

8	Operating Temperature	-10°C ~+ 50°C
9	Storage Temperature	-20°C ~+ 60°C
10	Relative Humidity	0~95% ~+ 35°C
11	Waterproof	Non-applied
12	Lighting Protection	Non-applied
13	RoHS Applicant	Applied
14	Safety	ETS300019
15	Environment	EN60950

MECHANICAL SPECIFICATIONS

17	Dimensions	W 482 × D 620 × H 265.9 (Not included projecting parts)		mm	
18	Weight	20 Kg			
19	Connector	Antenna 1,2	DIN Female	Port 1&&2&3&4	DIN Female
20	Mouting Type	6U×19inch rack mounted			

DRAWING

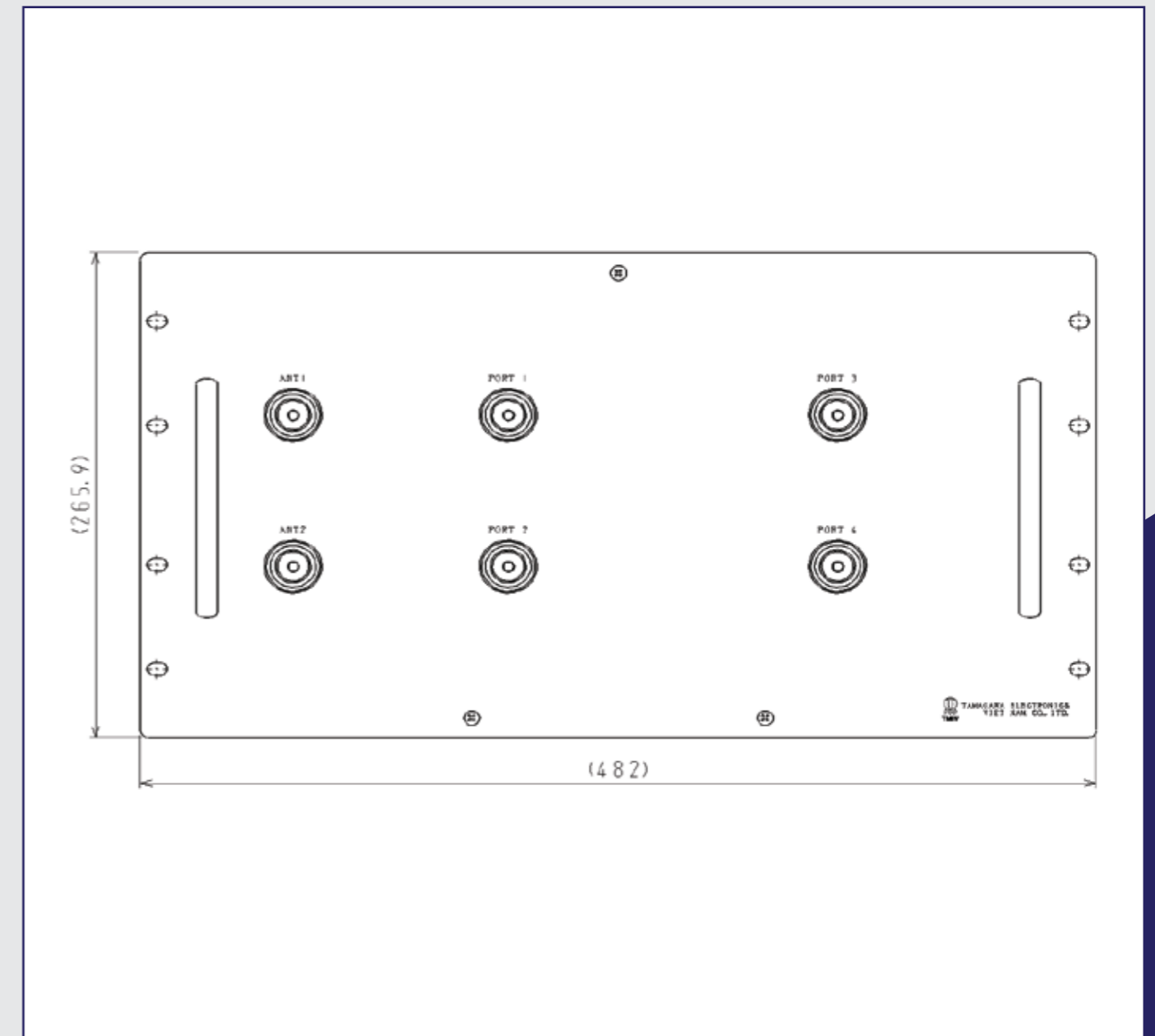

CEC-1002 SPECIFICATIONS

PRODUCT	POI (6INPUT 2OUT)	CEC-1002-030
MODEL	CEC-1002	

FEATURE

This POI has a configuration of 6 inputs and 2 outputs. The frequency can be manufactured from 700/900/1800/2100/2700 MHz with the specified frequency of GSM / WCDMA / LTE system. It is suitable for IBS base station products.

BLOCK DIGRAM

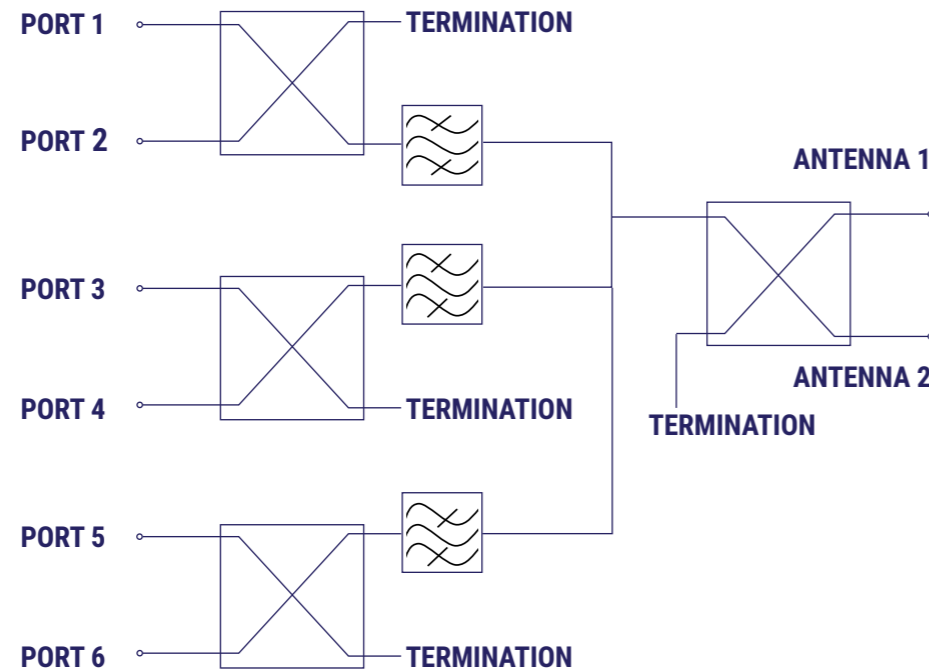

6 INPUT
2 OUT

ELECTRONICAL SPECIFICAITONS

NO	COLUMN	PORT 1,2	PORT 3,4	PORT 5,6
1	Pass band frequency	※ 700 ~ 900MHz	※ 700 ~ 900MHz	※ 700 ~ 900MHz
		※ 1700 ~ 1880MHz	※ 1700 ~ 1880MHz	※ 1700 ~ 1880MHz
		※ 1920 ~ 2200MHz	※ 1920 ~ 2200MHz	※ 1920 ~ 2200MHz
		※ 2500 ~ 2700MHz	※ 2500 ~ 2700MHz	※ 2500 ~ 2700MHz
Please designate the one pass band frequency from above ※ Passband is permitted within 10% of above each frequency band Port 1,Port2 and Port3 must not be same Pass band frequency				
2	Insertion Loss	9.5dB MAX	9.5dB MAX	9.5dB MAX
3	V.S.W.R.	1.35 MAX	1.35 MAX	1.35 MAX
5	In Band	23dBc Min	23dBc Min	23dBc Min
	Inter Bands	50dBc Min	50dBc Min	50dBc Min
6	Impedance	50Ω		
7	PIMD	-153dBc CW 2×43dBm		
8	Average Maximum Power	80W MAX. per input port		
		320W MAX. Total input power at +22°C room temp.		

ENVIORNMENTAL SPECIFICATIONS

9	Operating Temperature	-10°C ~+ 50°C
10	Storage Temperature	-20°C ~+ 60°C
11	Relative Humidity	0~95% ~+ 35°C
12	Waterproof	Non-applied
13	Lighting Protection	Non-applied
14	RoHS Applicant	Applied
15	Safety	ETS300019
16	Environment	EN60950

MECHANICAL SPECIFICATIONS

17	Dimensions	W 482 × D 620 × H 265.9 (Not included projecting parts)		mm	
18	Weight	25 kg (not included Mounting Metal Part)			
19	Connector	Antenna 1,2	DIN Female	Port 1&2	DIN Female
20	Mouting Type	6U×19inch rack mounted			

DRAWING

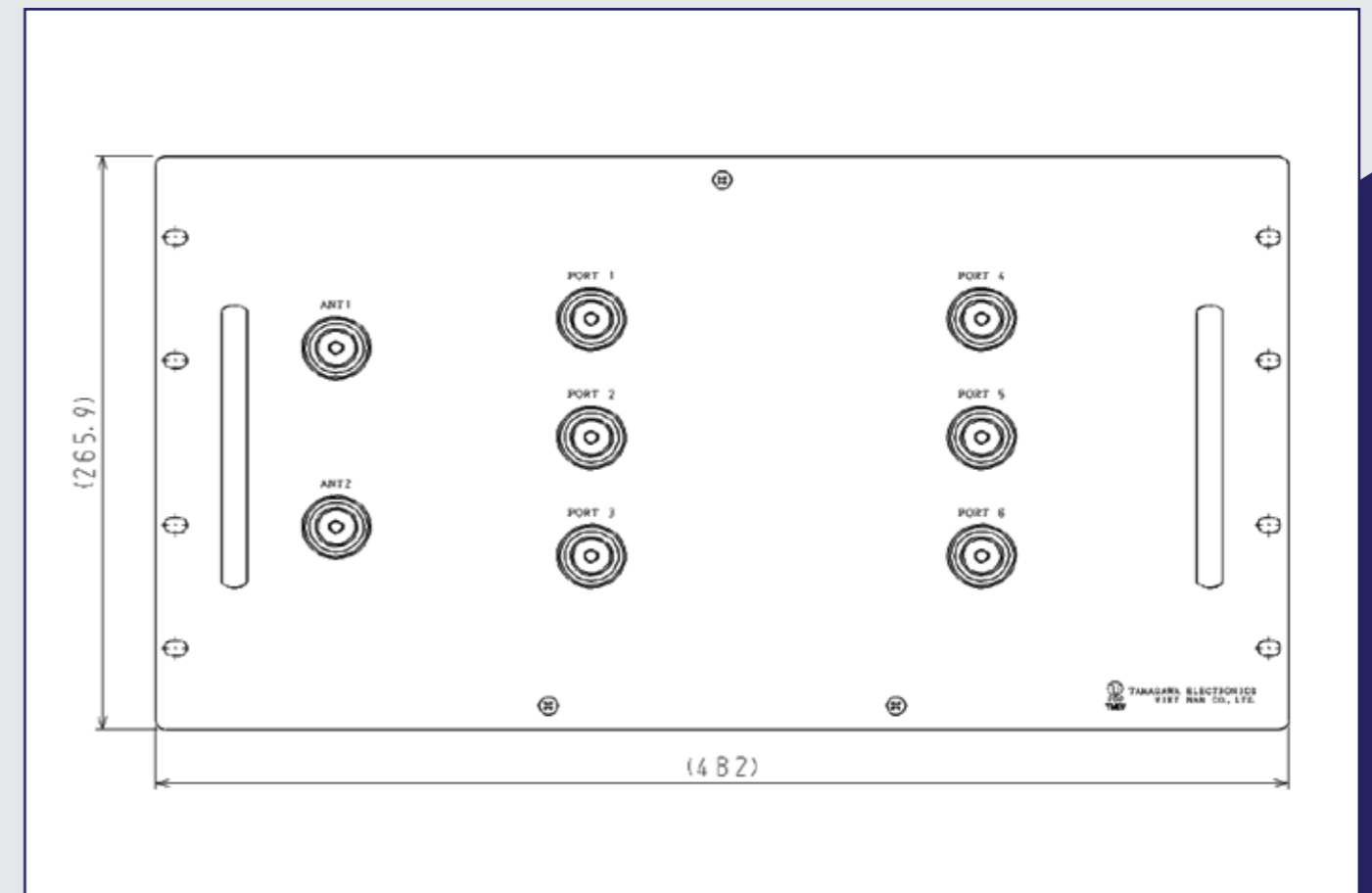

CEC-1003 SPECIFICATIONS

PRODUCT	POI (8INPUT 2OUT)	CEC-1003-030
MODEL	CEC-1003	

FEATURE

This POI is composed of 8 inputs and 2 outputs. The frequency can be manufactured from 700/900/1800/2100/2700 MHz with the specified frequency of GSM / WCDMA / LTE system. It is suitable for IBS base station products.

BLOCK DIGRAM

**8 INPUT
2 OUT**

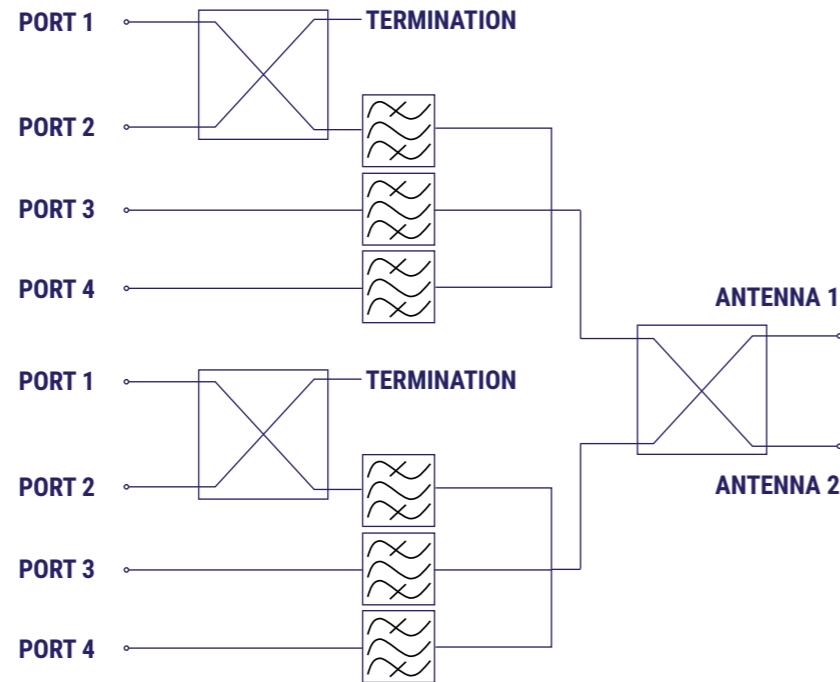

ELECTRONICAL SPECIFICAITONS

NO	COLUMN	PORT 1,2	PORT 3	PORT 4
1	Pass band frequency	※ 700 ~ 900MHz	※ 700 ~ 900MHz	※ 700 ~ 900MHz
		※ 1700 ~ 1880MHz	※ 1700 ~ 1880MHz	※ 1700 ~ 1880MHz
		※ 1920 ~ 2200MHz	※ 1920 ~ 2200MHz	※ 1920 ~ 2200MHz
		※ 2500 ~ 2700MHz	※ 2500 ~ 2700MHz	※ 2500 ~ 2700MHz
Please designate the one pass band frequency from above ※ Passband is permitted within 10% of above each frequency band Port 1,Port 2 must not be same Pass band frequency ※ Please choice the radio band to 13% of pass band frequency				
2	Insertion Loss	9.5dB MAX	9.5dB MAX	9.5dB MAX
3	V.S.W.R.	1.35 MAX	1.35 MAX	1.35 MAX
5	In Band	23dBc Min	23dBc Min	23dBc Min
	Inter Bands	50dBc Min	50dBc Min	50dBc Min
6	Impedance	50Ω		
7	PIMD	-153dBc CW 2×43dBm		
8	Average Maximum Power	80W MAX. per input port		
		320W MAX. Total input power at +22°C room temp.		

ENVIROMENTAL SPECIFICATIONS

9	Operating Temperature	-10°C ~+ 50°C
10	Storage Temperature	-20°C ~+ 60°C
11	Relative Humidity	0~95% ~+ 35°C
12	Waterproof	Non-applied
13	Lighting Protection	Non-applied
14	RoHS Applicant	Applied
15	Safety	ETS300019
16	Environment	EN60950

MECHANICAL SPECIFICATIONS

17	Dimensions	W 482 × D 620 × H 265.9 (Not included projecting parts)			mm
18	Weight	25 kg (not included Mounting Metal Part)			
19	Connector	Antenna	DIN Female	Port 1&2	DIN Female
20	Mouting Type	6U×19inch rack mounted			

DRAWING

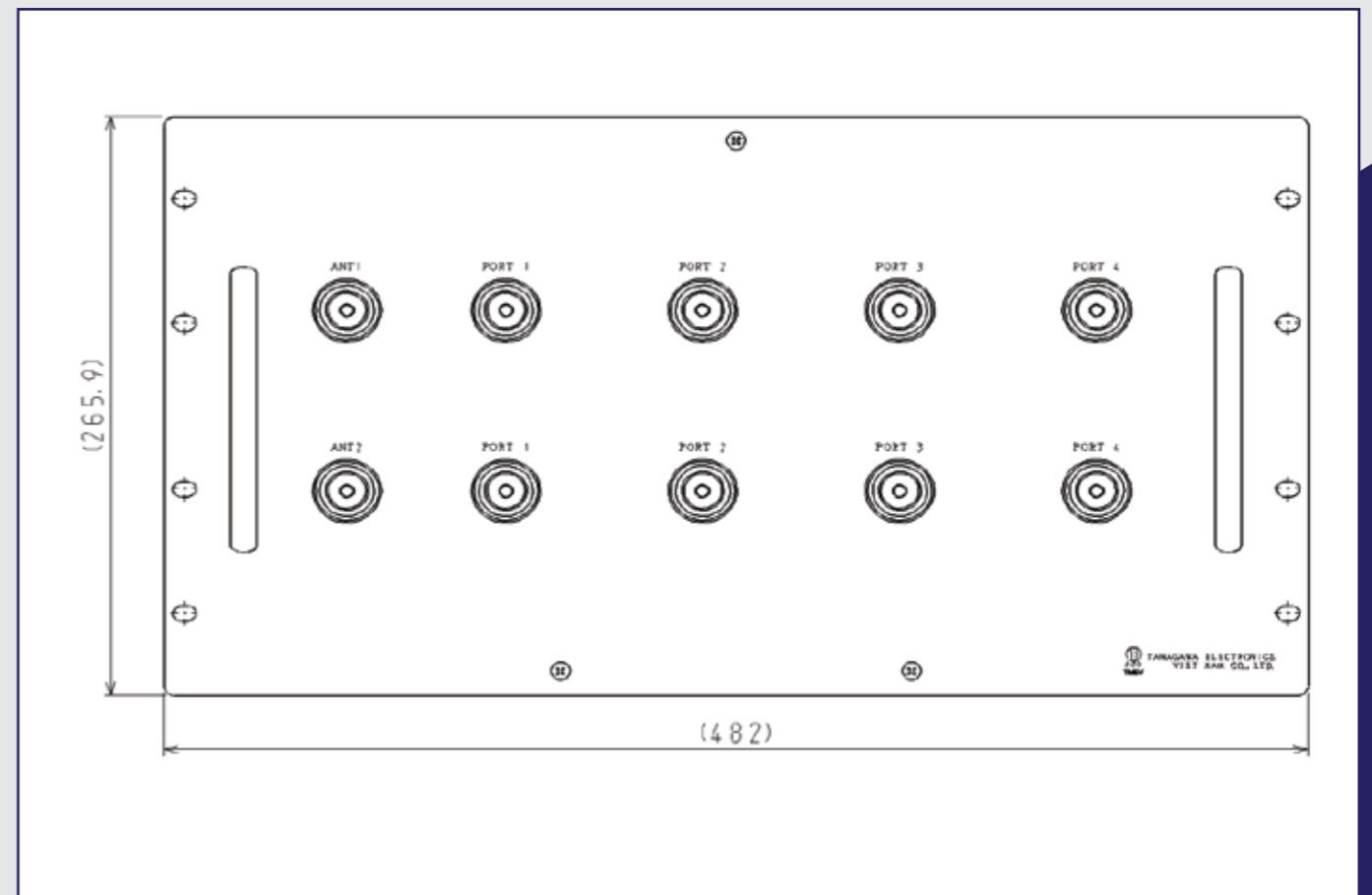

16 Input POI SPECIFICATIONS

Product	POI (16INPUT 2OUT)	TMEV-OC 16120-B137 POI
Model	TMEV-OC 16120-B137 POI	

FEATURE

POI is composed of 16 inputs and 2 outputs. The frequency can be manufactured from 700/900/1800/2100/2700 MHz with the specified frequency of GSM / WCDMA / LTE system. It is suitable for IBS base station products requiring multiple input ports.



**16INPUT
2OUT**

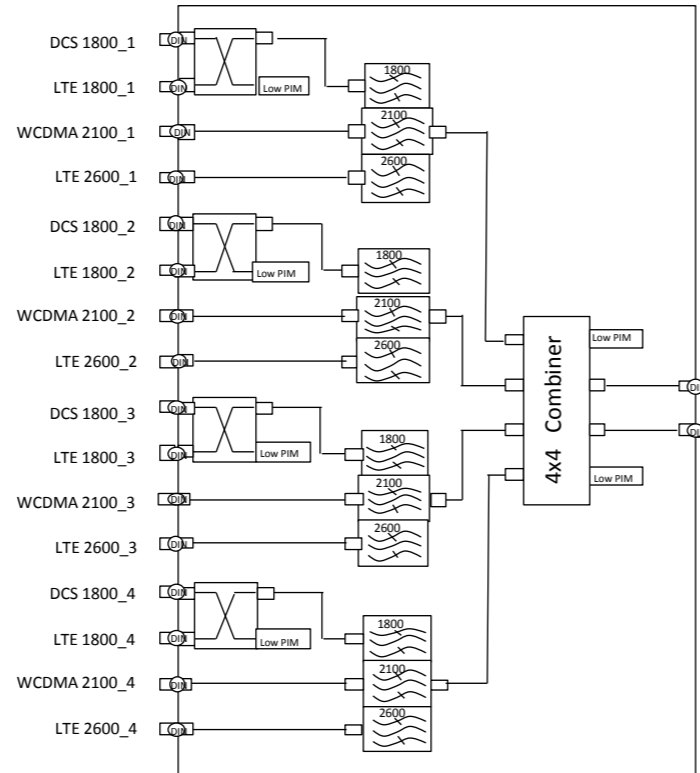

ELECTRONICAL SPECIFICATIONS

NO	COLUMN	DCS1800	WCDMA	LTE	
1	Pass band frequency	DCS1800*4PORTS	WCDMA2100*4PORTS	LTE1800:4PORTS	
		LTE1800 * 4PORTS		LTE2600*4PORTS	
		※Passband is permitted within 10% of above each frequency band			
		Port 1 and Port2 must not be same Pass band frequency			
		※Please choice the radio band to 13% of pass band frequency			
2	Insertion Loss	12.5dB MAX		9.0dB MAX	
3	V.S.W.R.	1.35 MAX		1.35 MAX	
4	Isolation	In Band		23dB Min	
		Inter Bands	50dB Min	50dB Min	
5	Impedance	50Ω			
6	PIMD	-150dBc CW 2x43dBm			
7	Average Maximum Power	80W MAX. per input port			
		320W MAX. Total input power at +22°C room temp.			

ENVIRONMENTAL SPECIFICATIONS

8	Operating Temperature	-10 °C ~ +50 °C
9	Storage Temperature	-20 °C ~ +60 °C
10	Relative Humidity	95 % non-condensing
11	Waterproof	Non-applied
12	Lighting Protection	Non-applied
13	RoHS Applicant	Applied
14	Safety	ETS300019
15	Environment	EN60950

MECHANICAL SPECIFICATIONS

16	Dimensions	6Ux19inch rack maounted			
17	Connector	Antenna	DIN Female	Port 1&2	DIN Female
18	Mouting Type	6Ux19inch rack maounted			

DRAWING

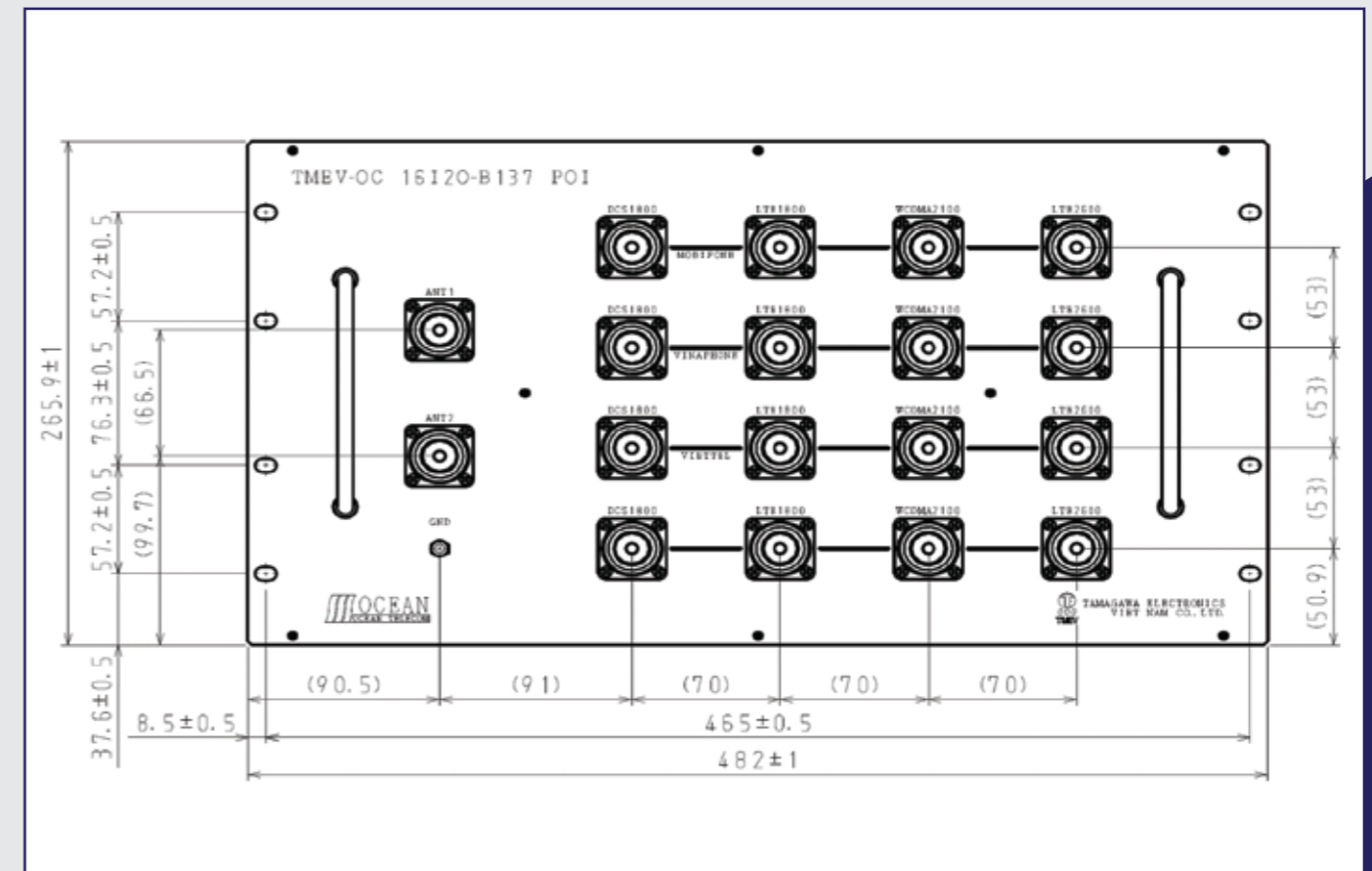

MIMO POI SPECIFICATIONS

Product	MIMO POI		
Model			

FEATURE

POI for Active DAS. This product can control the input level of the DAS equipment, and the level can be adjusted from the attenuator on the front panel. It has a function of attenuation of 41 dB at the maximum and it is an optimum POI for ACTIVE DAS system for IBS base station.

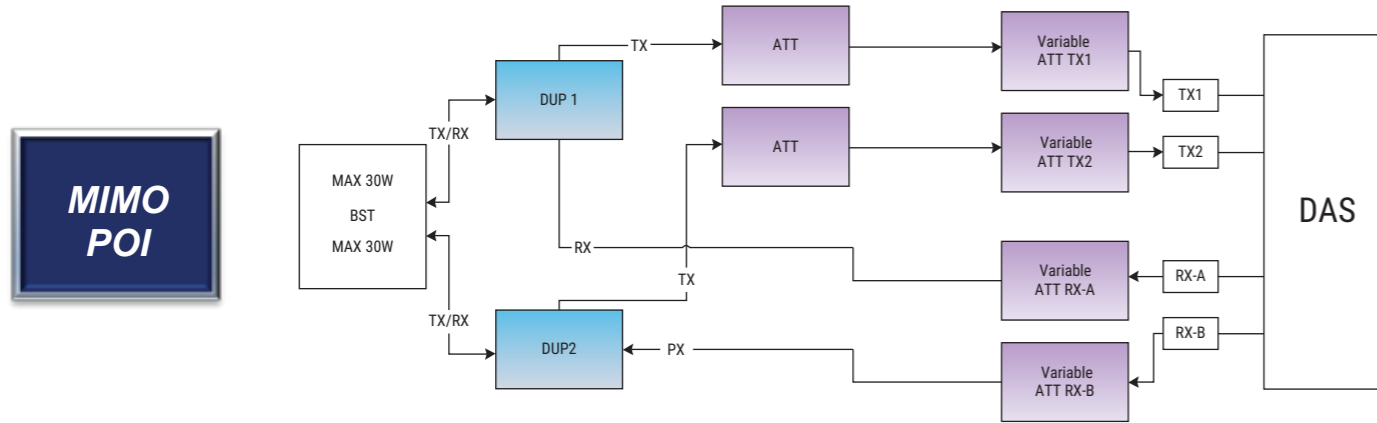

ELECTRONICAL SPECIFICATIONS

NO	Column	Frequency
1	Pass band frequency	LTE1800MHz
		LTE 2600MHz
		※Passband is permitted within 10% of above each frequency band
		Port 1 and Port2 must not be same Pass band frequency
		※Please choice the radio band to 13% of pass band frequency
2	Insertion Loss	TX/RX→TX : 25dB MAX RX→TX/RX : 10dB MAX
3	V.S.W.R.	1.3 MAX
4	Isolation Inter Bands	50dB Min
5	Level adjust	To DAS (Tx for A & B port) 1 to 41dB att To BTS (Rx for A & B port) 1 to 41dB att
6	Impedance	50Ω
7	Average Maximum Power	30W MAX. per input port (TX/RX1,TX/RX2) 1W MAX. per input port (TX1,TX2,RX1,RX2)

ENVIRONMENTAL SPECIFICATIONS

8	Operating Temperature	-10°C ~+50°C
9	Storage Temperature	-20°C ~+60°C
10	Relative Humidity	95% non-condensing

MECHANICAL SPECIFICATIONS

11	Dimensions	W482 x D450 x H88			
12	Connector	BTS SIDE	N-FEMALE	DAS SIDE	N-FEMALE
13	Mouting Type	2U×19inch rack maounted			

MECHANICAL SPECIFICATIONS

11	Dimensions	W482 x D450 x H88			
12	Connector	BTS SIDE	N-FEMALE	DAS SIDE	N-FEMALE
13	Mouting Type	2U×19inch rack maounted			

DRAWING

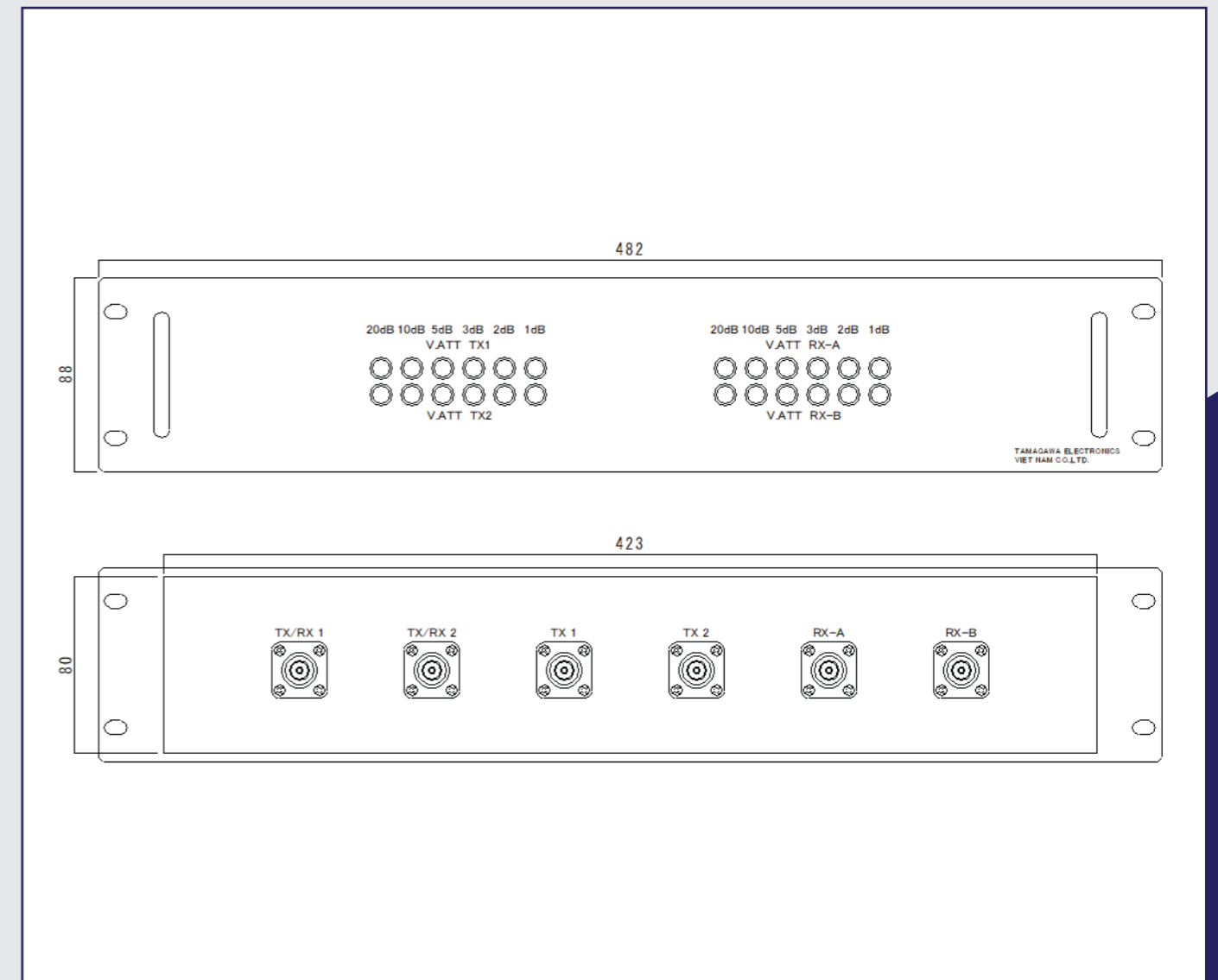

UT-1000 SERIES SPECIFICATIONS

PRODUCT	TERMINATOR
MODEL	UT Series

FEATURE

UT - 1000 series are coaxial nonreflective terminator with an allowable power of 50W and 100 W. The operating frequency range can be used from DC to 3000 MHz.

DRAWING

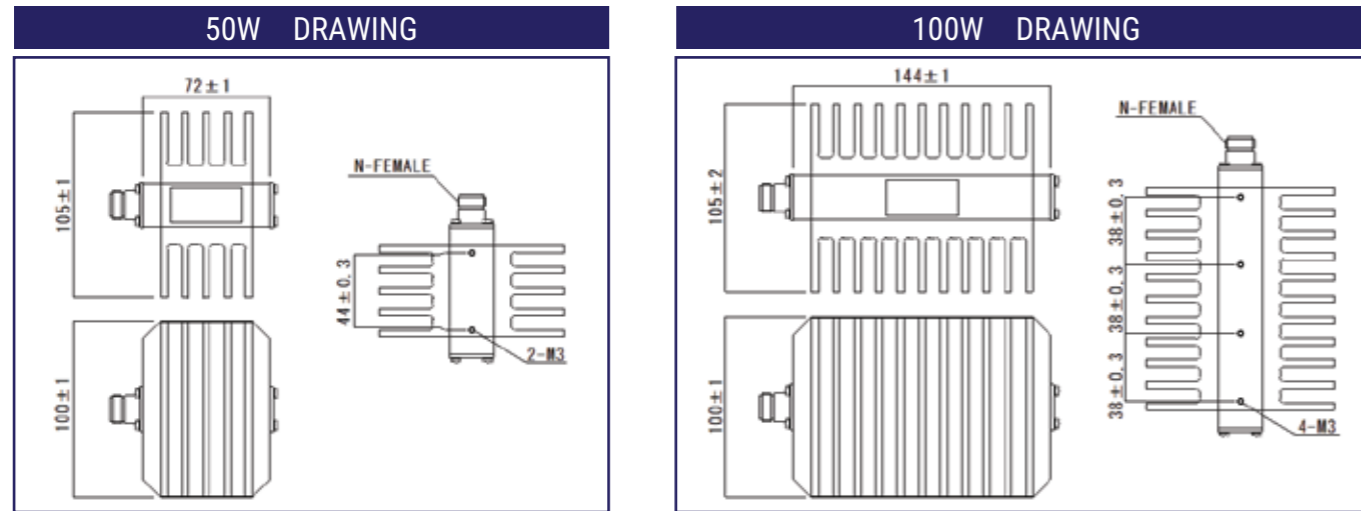

ELECTRONICAL SPECIFICATIONS

NO	Model	UT - 1001	UT - 1000
2	Frequency	DC - 3000MHz	
3	V.S.W.R	1.3	
4	Impedance	50Ω	
5	Average MAX Power	50W	100W

ENVIRONMENTAL SPECIFICATIONS

6	Operating Temperature	-10 ~ 50 °C
7	Storage Temperature	-10 ~ 60 °C
8	Relative Humidity	5 ~ 95%RH @+35°C
9	RoHS Applicant	Applied
10	Safety	ETS300019
11	Environment	EN60950

MECHANICAL SPECIFICATIONS

13	Dimensions(mm)	Refer to Drawing outline	
14	Weight	1050g	2250g
15	Connector	N-FEMALE	
16	Mounting Type	2-M3	4-M3

UFA-SERIES SPECIFICATIONS

PRODUCT	FIXED ATTENUATOR
MODEL	UFA Series

FEATURE

UFA - 1000 series are a coaxial attenuator with an allowable power of 50W and 100 W. The operating frequency range can be used from DC to 3000 MHz. It is suitable for measurement and IBS solutions. The variety of attenuations are 3,6,10,20,30dB.

DRAWING

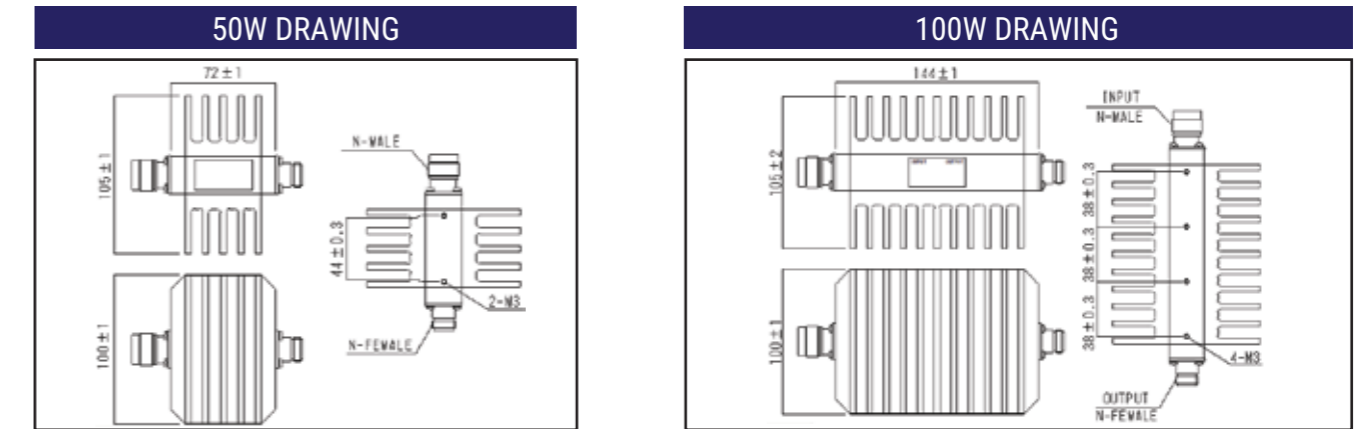

ELECTRONICAL SPECIFICATIONS

NO	Model	
1	Frequency	DC-3000MHz
2	Attenuation deviation	± (3%+0.5dB)
3	V.S.W.R	1.3
4	Attenuation	3,6,10,20,30dB
5	Impedance	50Ω
6	Average MAX Power	50W 100W

ENVIRONMENTAL SPECIFICATIONS

7	Operating Temperature	-10~50°C
8	Storage Temperature	-10~60°C
9	Relative Humidity	5~95%RH @+35°C
10	RoHS Applicant	Applied
11	Safety	ETS300019
12	Environment	EN60950

MECHANICAL SPECIFICATIONS

14	Dimensions(mm)	Refer to Drawing outline	
15	Weight	1050g	2250g
16	Connector	Input: N-male Output: N-female	
17	Mounting Type	2-M3	4-M3

CONTACT

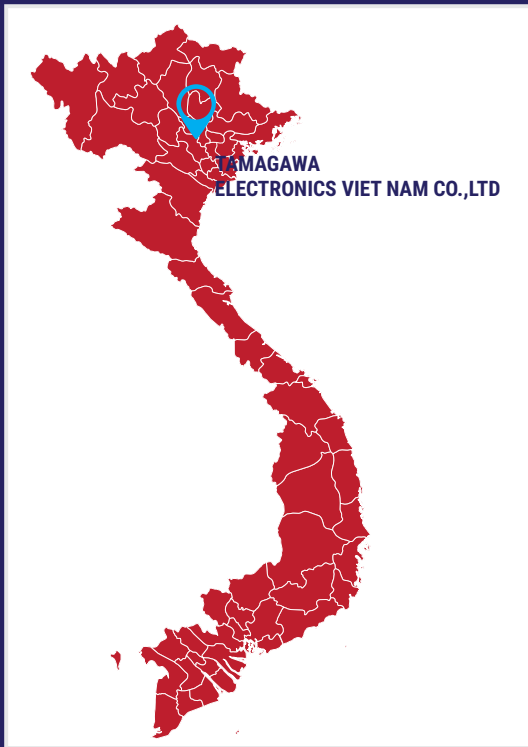

TAMAGAWA ELECTRONICS VIET NAM CO.,LTD

RF NO.7A, Plot No.H-1, Thang Long Industrial Park II
My Hao District, Hung Yen Province, Viet Nam

Tel: (+84)221-397-4545/46 * **Fax:** (+84)221-397-4547

TAX code: 0900918385

Web: www.tmev.com.vn

SALES OFFICE

DTG Building 5F 272-274 Hoa Hung street ,
Ward 13 District 10 Ho Chi Minh city Vietnam

Tel: 02838 683 278 * **Fax:** 02838 683 279

Tax code: 0900918385

ADDRESS: VIETNAM MANUFACTURE

TAMAGAWA ELECTRONICS CO.,LTD

252-1113

3-11-23, Kamitsutidana-naka Ayase City Kanagawa,Japan

Tel: (+81)467 - 76 - 2293 * **Fax:** (+81)467 - 70 - 4390

Web: www.tmele.jp

