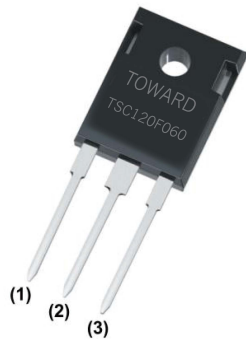


# TSC120F060

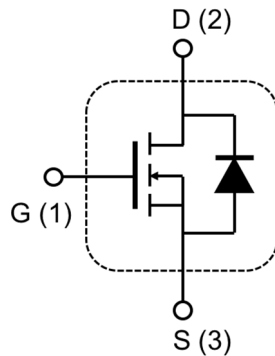
## Silicon Carbide Power MOSFET

N-CHANNEL ENHANCEMENT MODE

TO-247-3L



Inner Circuit



Product Summary

$V_{DS}$	<b>1200V</b>
$I_D(@25^{\circ}C)$	<b>41A</b>
$R_{DS(on)}$	<b>60m<math>\Omega</math></b>



### Features

- ◆ Low On-Resistance
- ◆ Low Capacitance
- ◆ Avalanche Ruggedness
- ◆ Halogen Free, RoHS Compliant

### Applications

- ◆ SMPS / UPS / PFC
- ◆ EV Charging station & Motor Drives

### Benefits

- ◆ Higher System Efficiency
- ◆ Parallel Device Convenience
- ◆ High Temperature Application
- ◆ High Frequency Operation
- ◆ Power Inverters & DC/DC Converters
- ◆ Solar/ Wind Renewable Energy

### Maximum Ratings ( $T_c=25^{\circ}C$ )

Parameter	Symbol	Test Conditions	Value	Unit
Drain – Source Voltage	$V_{DS, max}$	$V_{GS}=0V, I_{DS}=100\mu A$	1200	V
Continuous Drain Current	$I_D$	$V_{GS}=20V, T_C=25^{\circ}C$	41	A
		$V_{GS}=20V, T_C=110^{\circ}C$	25	
Pulse Drain Current	$I_{D, pulse}$	$t_{PW}$ limitation per Fig.17	138	
Avalanche energy, Single Pulse	$E_{AS}$	$V_{DD}=100V, I_D=10A$	1250	mJ
Power Dissipation	$P_D$	$T_C=25^{\circ}C$	208	W
Recommend Gate Source Voltage	$V_{GS, op}$		-5/+20	V
Maximum Gate Source Voltage	$V_{GS, max}$		-10/+25	
Junction & Storage Temperature	$T_j, T_{stg}$		-55/+150	$^{\circ}C$
Soldering Temperature	$T_L$		260	

### Electrical Characteristics (T<sub>j</sub>=25°C)

Parameter	Symbol	Test Conditions	Min.	Typ.	Max.	Unit
Drain-Source Breakdown Voltage	V <sub>(BR)DSS</sub>	V <sub>GS</sub> =0V, I <sub>DS</sub> =100μA	1200			V
Gate Threshold Voltage	V <sub>GS(th)</sub>	V <sub>DS</sub> =10V, I <sub>DS</sub> =10mA		2.4		V
Zero Gate Voltage Drain Current	I <sub>DSS</sub>	V <sub>DS</sub> =1200V, V <sub>GS</sub> =0V		<1	50	μA
		V <sub>DS</sub> =1200V, V <sub>GS</sub> =0V T <sub>j</sub> =150°C		5	200	
Gate-Source Leakage Current	I <sub>GSS</sub>	V <sub>GS</sub> =20V, V <sub>DS</sub> =0V			250	nA
Drain-Source On-State Resistance	R <sub>DS(on)</sub>	V <sub>GS</sub> =20V, I <sub>DS</sub> =20A		60	80	mΩ
		V <sub>GS</sub> =20V, I <sub>DS</sub> =20A, T <sub>j</sub> =150°C		95		
Input Capacitance	C <sub>iss</sub>	V <sub>GS</sub> =0V, V <sub>DS</sub> =800V f=1MHz, V <sub>AC</sub> =25mV		1800		pF
Output Capacitance	C <sub>oss</sub>			104		
Reverse Transfer Capacitance	C <sub>rss</sub>			16		
Effective Output Capacitance, Energy Related	C <sub>o(er)</sub>	V <sub>GS</sub> =0V, V <sub>DS</sub> =0 to 800V		131		
Effective Output Capacitance, Time Related	C <sub>o(tr)</sub>	I <sub>D</sub> =const., V <sub>GS</sub> =0V, V <sub>DS</sub> =0 to 800V		180		
Turn On Delay Time	t <sub>d(on)</sub>	V <sub>DS</sub> =800V, V <sub>GS</sub> =-4/+20V, I <sub>D</sub> =20A, R <sub>L</sub> =40Ω, R <sub>G(ext)</sub> = 2.7 Ω		25		ns
Rise Time	t <sub>r</sub>			24		
Turn Off Delay Time	t <sub>d(off)</sub>			20		
Fall Time	t <sub>f</sub>			9		
C <sub>oss</sub> Stored Energy	E <sub>oss</sub>	V <sub>GS</sub> =0V, V <sub>DS</sub> =800V f=1MHz, V <sub>AC</sub> =25mV		58*		μJ
Turn-on Switching Energy	E <sub>on</sub>	V <sub>DS</sub> =800V, V <sub>GS</sub> =0/20V, I <sub>D</sub> =20A, R <sub>G(ext)</sub> = 2.7 Ω		115*		
Turn-off Switching Energy	E <sub>off</sub>			165*		
Internal Gate Resistance	R <sub>G(int.)</sub>	f=1MHz, V <sub>AC</sub> =25mV		1.2		Ω

\*Base on the results of calculation, note that the energy loss caused by the reverse recovery of FWD is not included in E<sub>on</sub>.

### Built-in SiC Diode Characteristics (T<sub>j</sub>=25°C)

Parameter	Symbol	Test Conditions	Typ.	Unit
Inverse Diode Forward Voltage	V <sub>SD</sub>	V <sub>GS</sub> =-5V, I <sub>SD</sub> =5A	4.3	V
Continuous Diode Forward Current	I <sub>S</sub>	V <sub>GS</sub> =-5V, T <sub>C</sub> =25°C	33	A
Reverse Recovery Time	t <sub>rr</sub>	V <sub>GS</sub> =0V, I <sub>SD</sub> =20A, V <sub>DS</sub> =400V, di/dt=300A/μs	57	ns
Reverse Recovery Charge	Q <sub>rr</sub>		109	nC
Peak Reverse Recovery Current	I <sub>rrm</sub>		3.5	A

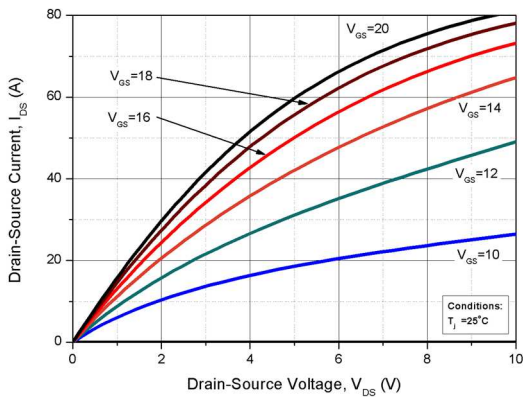
### Gate Charge Characteristics ( $T_j=25^\circ\text{C}$ )

Parameter	Symbol	Test Conditions	Value	Unit
Gate to Source Charge	$Q_{GS}$	$V_{DS}=800\text{V}$ , $V_{GS}=-5/+20\text{V}$ , $I_D=20\text{A}$	29	nC
Gate to Drain Charge	$Q_{GD}$		64	
Total Gate Charge	$Q_G$		129	
Gate plateau voltage	$V_{pl}$		6.95	V

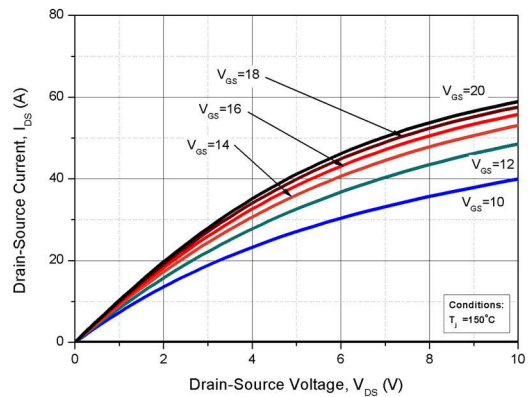
### Thermal Resistance

Parameter	Symbol	Value	Unit
Thermal Resistance, Junction to Case	$R_{\theta,JC}$	0.6	K/W

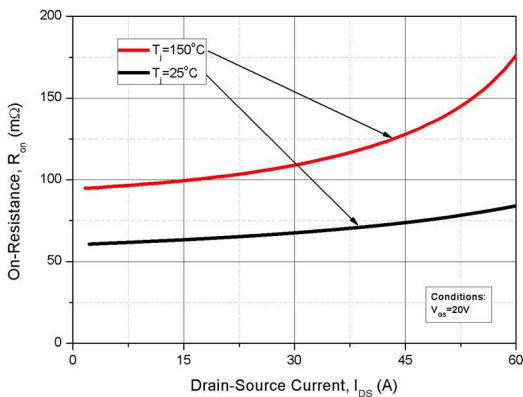
### Typical Device Performance



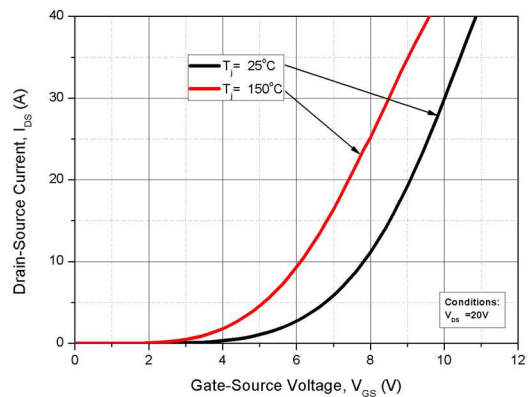
**Fig. 1 Forward Output Characteristics at  $T_j = 25^\circ\text{C}$**



**Fig. 2 Forward Output Characteristics at  $T_j = 150^\circ\text{C}$**

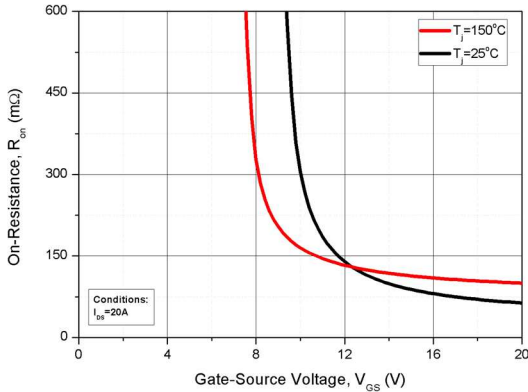


**Fig. 3 On-Resistance vs. Drain Current for Various  $T_j$**

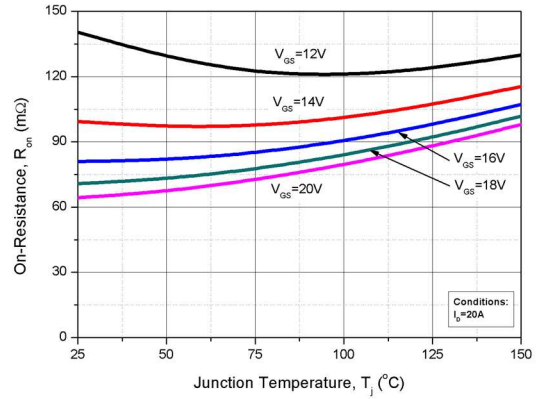


**Fig. 4 Transfer Characteristics for Various  $T_j$**

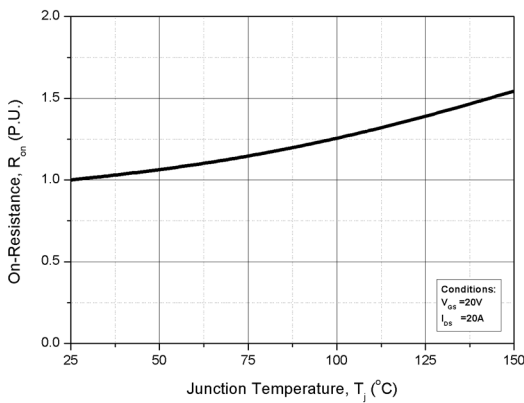
## Typical Device Performance



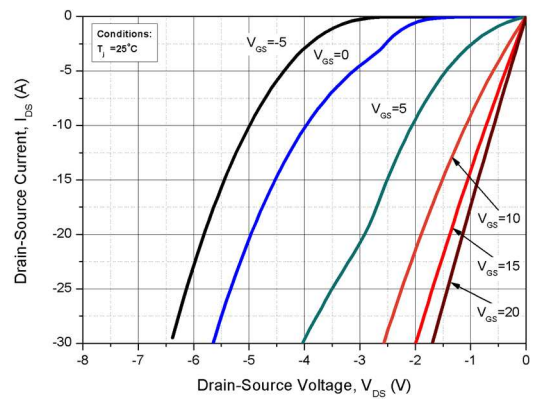
**Fig. 5 On-Resistance vs. Gate Voltage for Various  $T_j$**



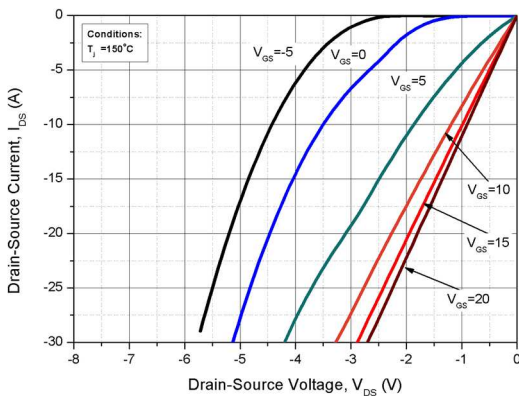
**Fig. 6 On-Resistance vs. Temperature for Various Gate Voltage**



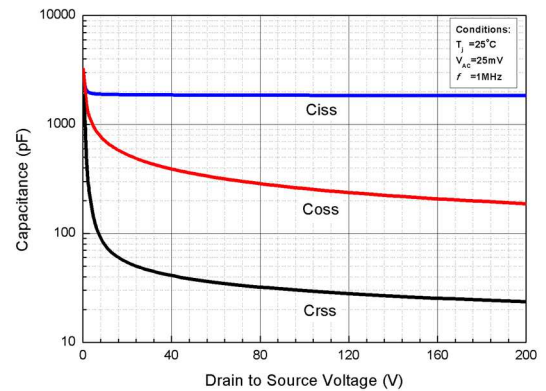
**Fig. 7 Normalized On-Resistance vs. Temperature**



**Fig. 8 Reverse Output Characteristics at  $T_j = 25^\circ\text{C}$**

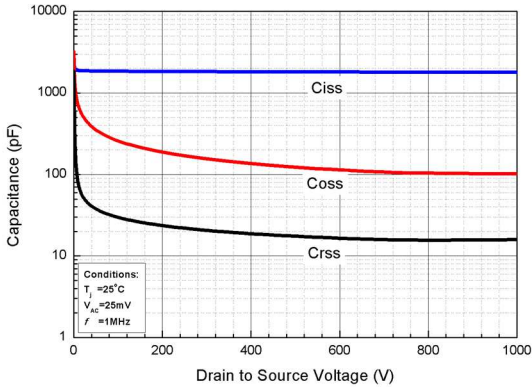


**Fig. 9 Reverse Output Characteristics at  $T_j = 150^\circ\text{C}$**

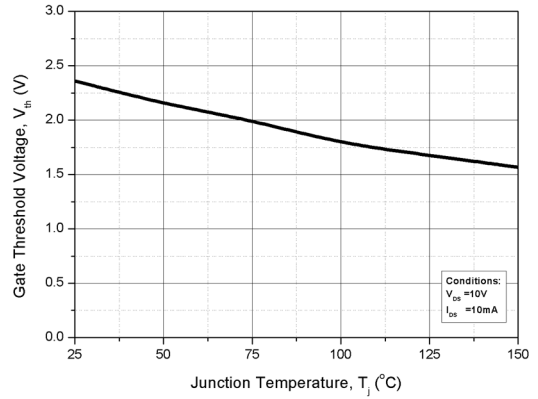


**Fig. 10 Capacitances vs. Drain to Source Voltage (0 - 200V)**

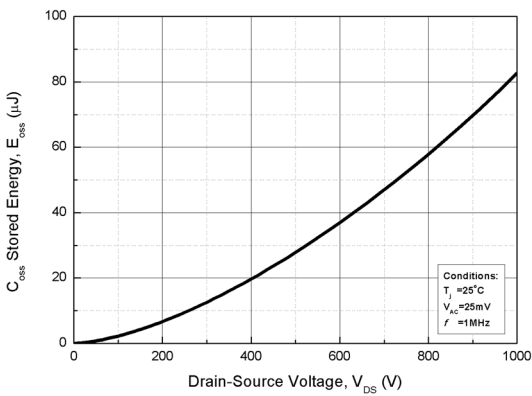
**Typical Device Performance**



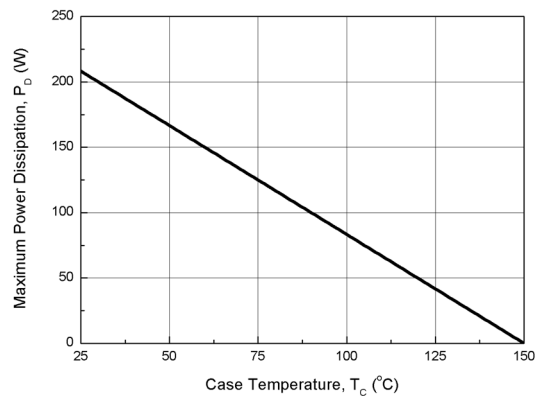
**Fig. 11 Capacitances vs. Drain to Source Voltage (0 - 1000V)**



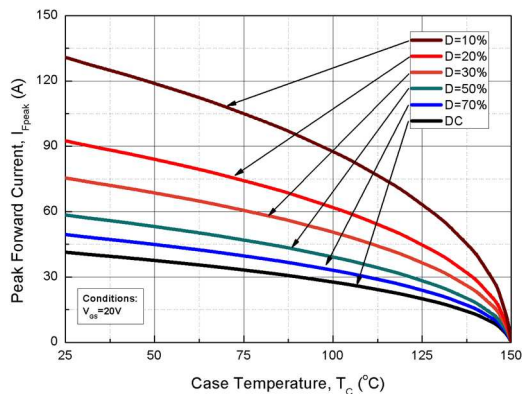
**Fig. 12 Threshold Voltage vs. Temperature**



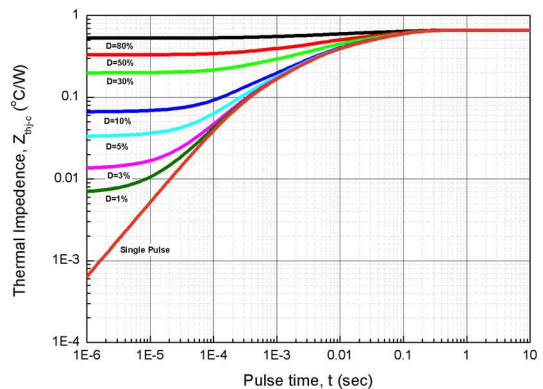
**Fig. 13 Output Capacitor Stored Energy\***



**Fig. 14 Maximum Power Dissipation Derating vs. Case Temperature**



**Fig. 15 Drain Current Derating vs. Case Temperature**



**Fig. 16 Transient Junction to Case Thermal Impedance**

## Typical Device Performance

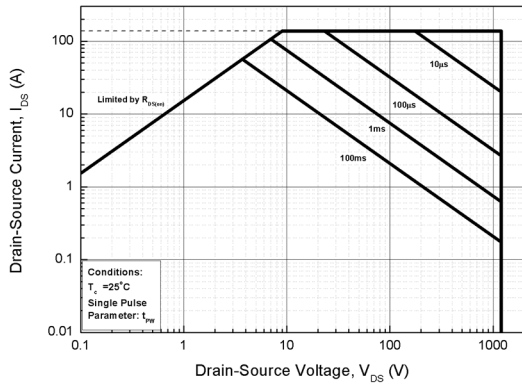


Fig. 17 Safe Operating Area

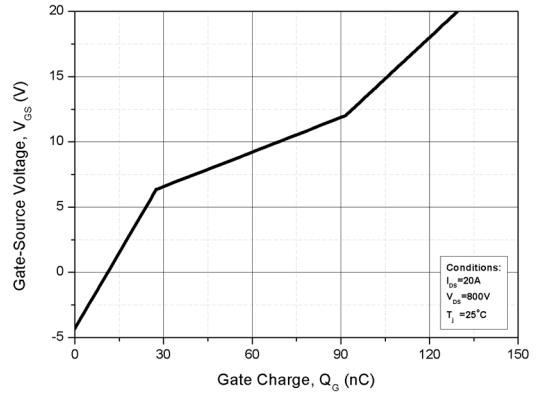


Fig. 18 Gate Charge Characteristics

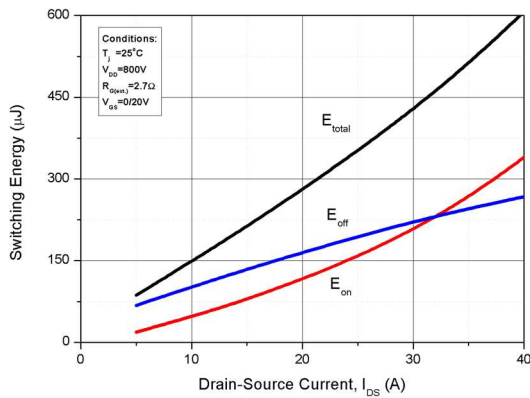


Fig. 19 Clamped Inductive Switching Energy vs. Drain Current ( $V_{DD} = 800\text{V}$ )\*

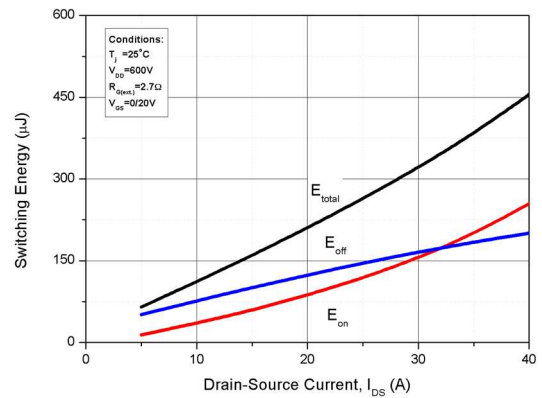


Fig. 20 Clamped Inductive Switching Energy vs. Drain Current ( $V_{DD} = 600\text{V}$ )\*

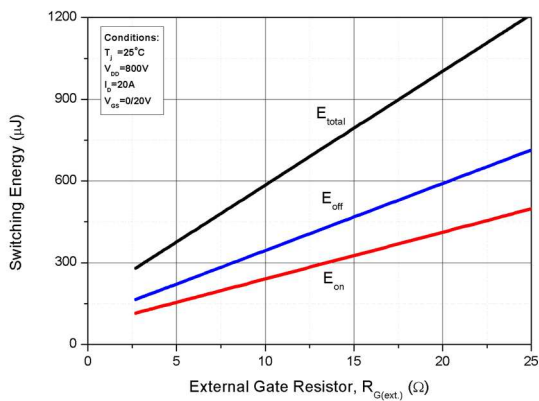
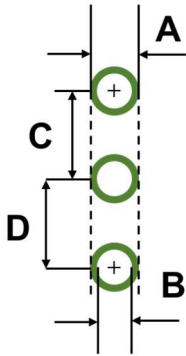


Fig. 21 Clamped Inductive Switching Energy vs. External Gate Resistor ( $R_{G(ext)}$ )\*

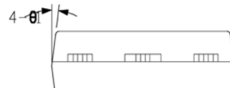
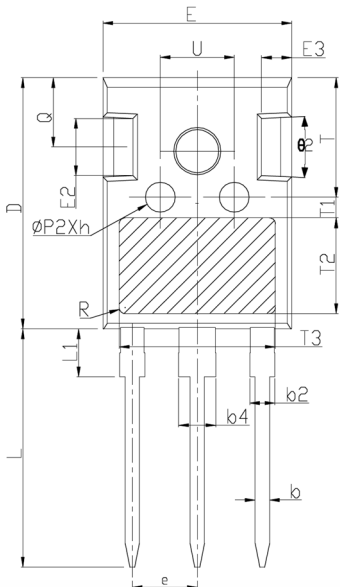
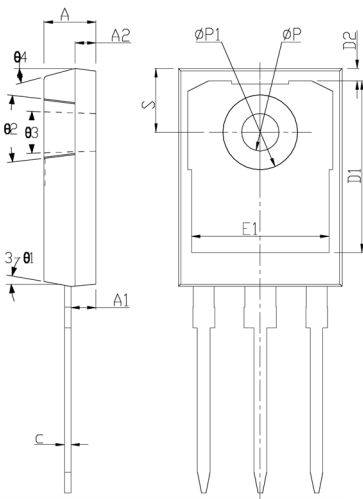
\*Base on the results of calculation, note that the energy loss caused by the reverse recovery of FWD is not included in  $E_{on}$ .

### Recommended Solder Pad Layout (TO-247-3L)



Mechanical Parameters			
Parameter	Symbol	Typical	Unit
Length	A	3.048	mm
	B	2.032	
	C	5.436	
	D	5.436	

### Mechanical Parameters



NOTES:  
 1. All dimensions are in mm.  
 2. Tolerance:  $\pm 0.05\text{mm}$ .

SYMBOL	DIMENSIONS IN MILLIMETERS		
	MIN	NOM	MAX
A	4.75	5.00	5.25
A1	2.16	2.41	2.66
A2	1.85	2.00	2.15
b	1.11	1.21	1.35
b2	1.90	2.01	2.25
b4	2.90	3.01	3.25
c	0.51	0.61	0.75
D	20.60	21.00	21.40
D1	16.15	16.55	16.95
D2	1.00	1.20	1.40
E	15.50	15.80	16.10
E1	13.00	13.30	13.60
E2	4.70	5.00	5.30
E3	2.25	2.50	2.75
e	5.44BSC		
h	0.00	0.10	0.25
L	19.52	19.92	20.32
L1	-	-	4.30
ØP	3.35	3.60	3.85
ØP1	-	-	7.30
ØP2	2.25	2.50	2.75
Q	5.50	5.80	6.10
S	6.15BSC		
R	0.50REF		
T	9.70	-	10.30
T1	1.65REF		
T2	8.00REF		
T3	12.80REF		
U	5.90	-	6.50
Ø1	4°	7°	10°
Ø2	2°	5°	8°
Ø3	1°	-	2°
Ø4	10°	15°	20°

\*The information provided herein is subject to change without notice.